

FROM GLOBAL SENSING IN A UBIQUITOUS DIGITAL SOCIETY TO QOS FOR CLOUD COMPUTING INFRASTRUCTURES

SEMINAR, GHPC GROUP
JULY, 27TH 2011
BÁCH KHOA UNIVERSITY



PROF. CONGDUC PHAM
[HTTP://WWW.UNIV-PAU.FR/~CPHAM](http://www.univ-pau.fr/~cpham)
UNIVERSITÉ DE PAU, FRANCE



CITY OF PAU



diaporama des
campus de l'UPPA





RESEARCH INTERESTS



Distributed &
Parallel
Simulation

Cluster
Computing, HP
Simulations,
Myrinet

Active Networks
Multicast,
Congestion
Control

TCP, High-
Speed
Networking
for GRID

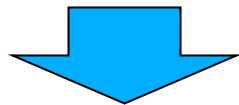

UNTIL 2007

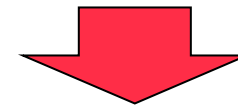

Apply networking techniques to enhance GRID infrastructures

Active Reliable Multicast, Active Grid Architecture, TCP for high-speed Grids,
Network QoS for Grid Applications

GRID



NETWORK



APPLICATION PEOPLE COME FROM VENUS, NETWORKING PEOPLE COME FROM MARS

Application guys

Apply networking techniques for GRID/ Cloud applications

Networking guys

The network is a

Don't care about

The dark side of TCP: understanding TCP on very high-speed networks, ACOMP'2008

High-speed networking: Enabling Grids and high performance computing, RIVF'2007

New Internet and Networking Technologies for Grids and High-Performance Computing, HotInterconnect'2006, HiPC'2004

New Internet and Networking Technologies and their Application to Computational Science, COSCI'2004



RESEARCH INTERESTS



Distributed & Parallel Simulation

Cluster Computing, HP Simulations, Myrinet

Active Networks Multicast, Congestion Control

TCP, High-Speed Networking for GRID

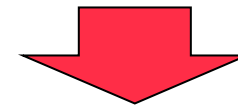

Apply networking techniques to enhance GRID infrastructures
Active Reliable Multicast, Active Grid Architecture, TCP for high-speed Grids, Network QoS for Grid Applications

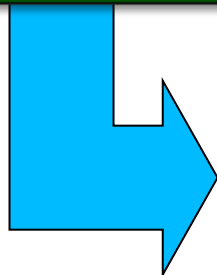

Global Sensing Infrastructures, Data Agregation, Large Data Sets, QoS & Cloud Computing

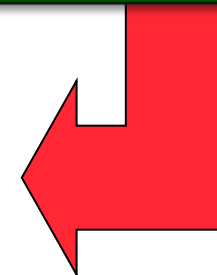



GRID RELATED PROJECTS



□ GRID/CLOUD FOR COMPANIES



WWW.PIREGRID.EU

□ LARGE DATA ISSUES (WORKFLOWS)

OMNIDATA





COMPUTATIONAL GRIDS



user (scientist)
application

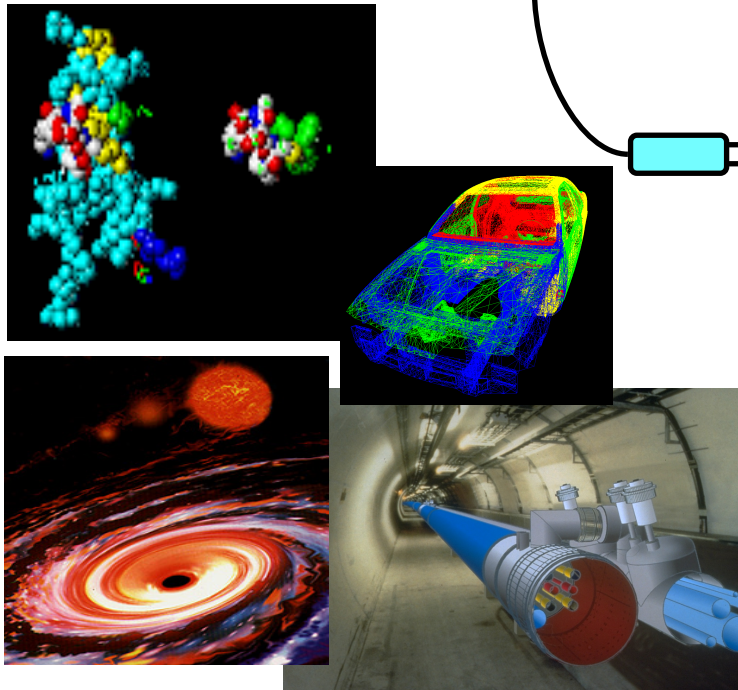

Virtually unlimited resources

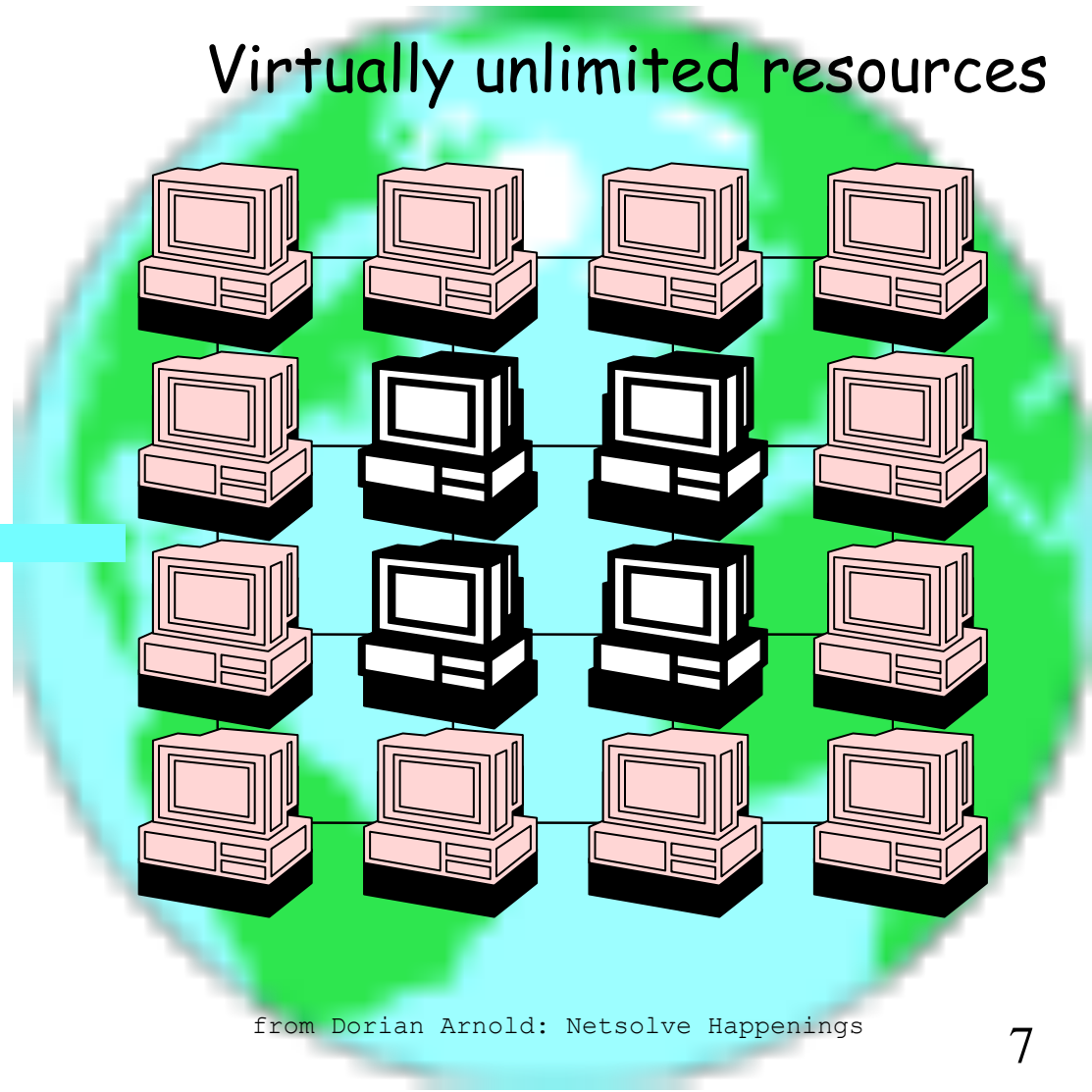

from Dorian Arnold: Netsolve Happenings



UBIQUITOUS CLOUDS



iCloud



Dropbox



Google



DIGITAL WIRELESS WORLD

Wi-Fi

Bluetooth

wimax

ZigBee®
Member

4G
100mbps-1GBps

3G

Lte™

WiMedia
ALLIANCE

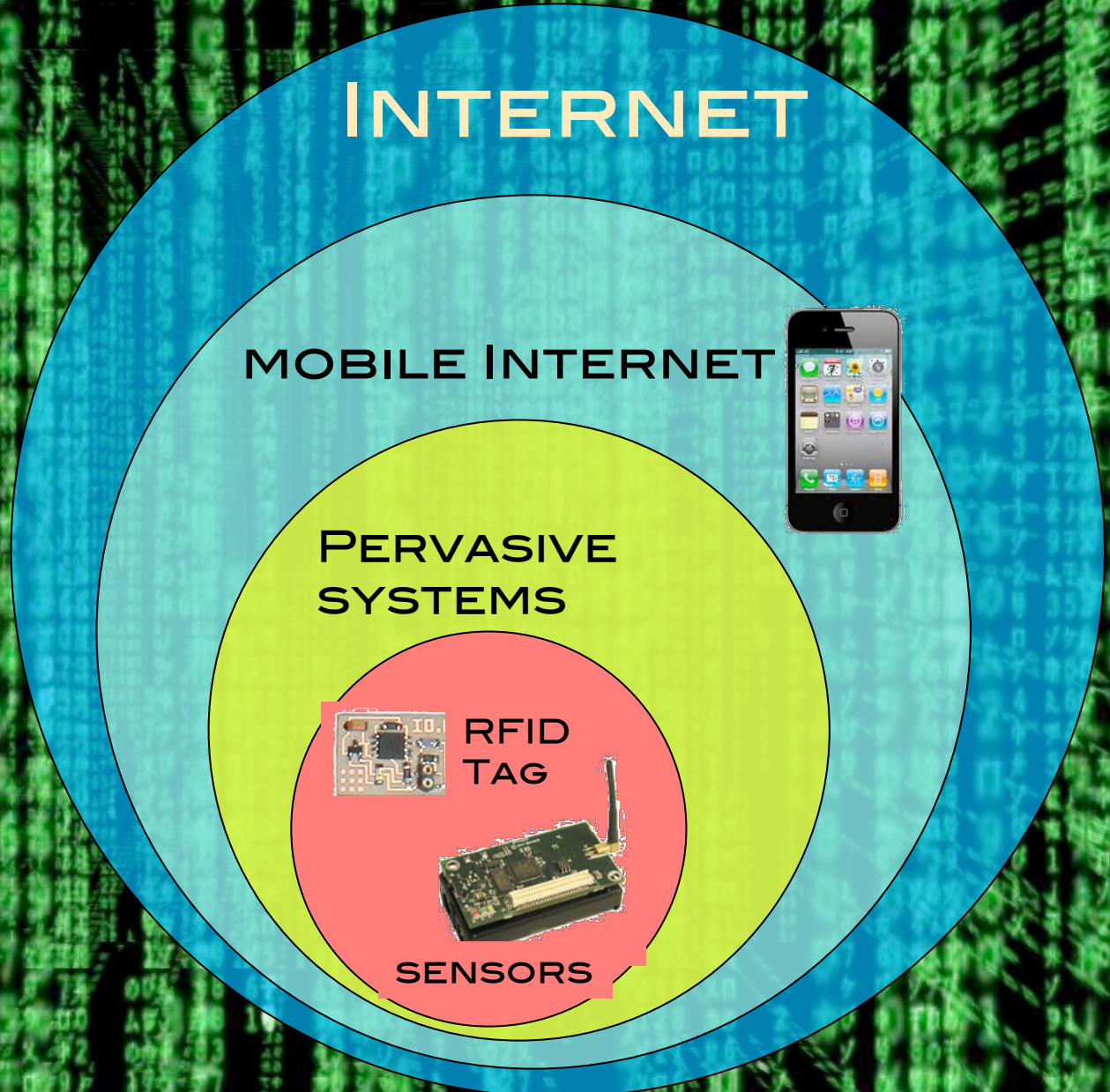



SMALL, SMART DEVICES!

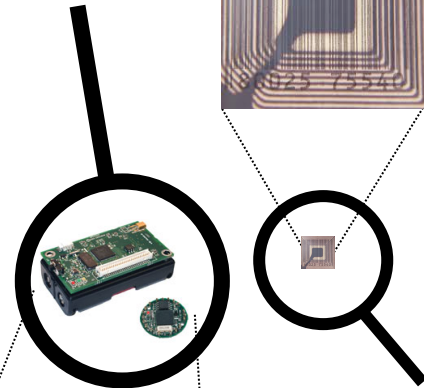

Autonomous sensors and RFID tag can be embedded in various structures or objects of our daily life to enhance localization, tracking and information collection.

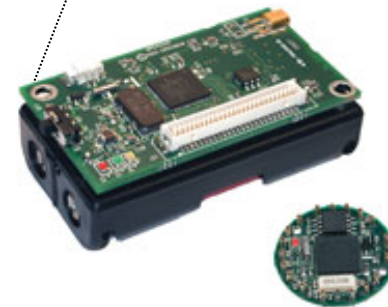



FROM SENSING...



SENSING





...TO DIGITAL SOCIETY...



PERVASIVE SYSTEMS



SENSING





...TO UBIQUITOUS WORLD...

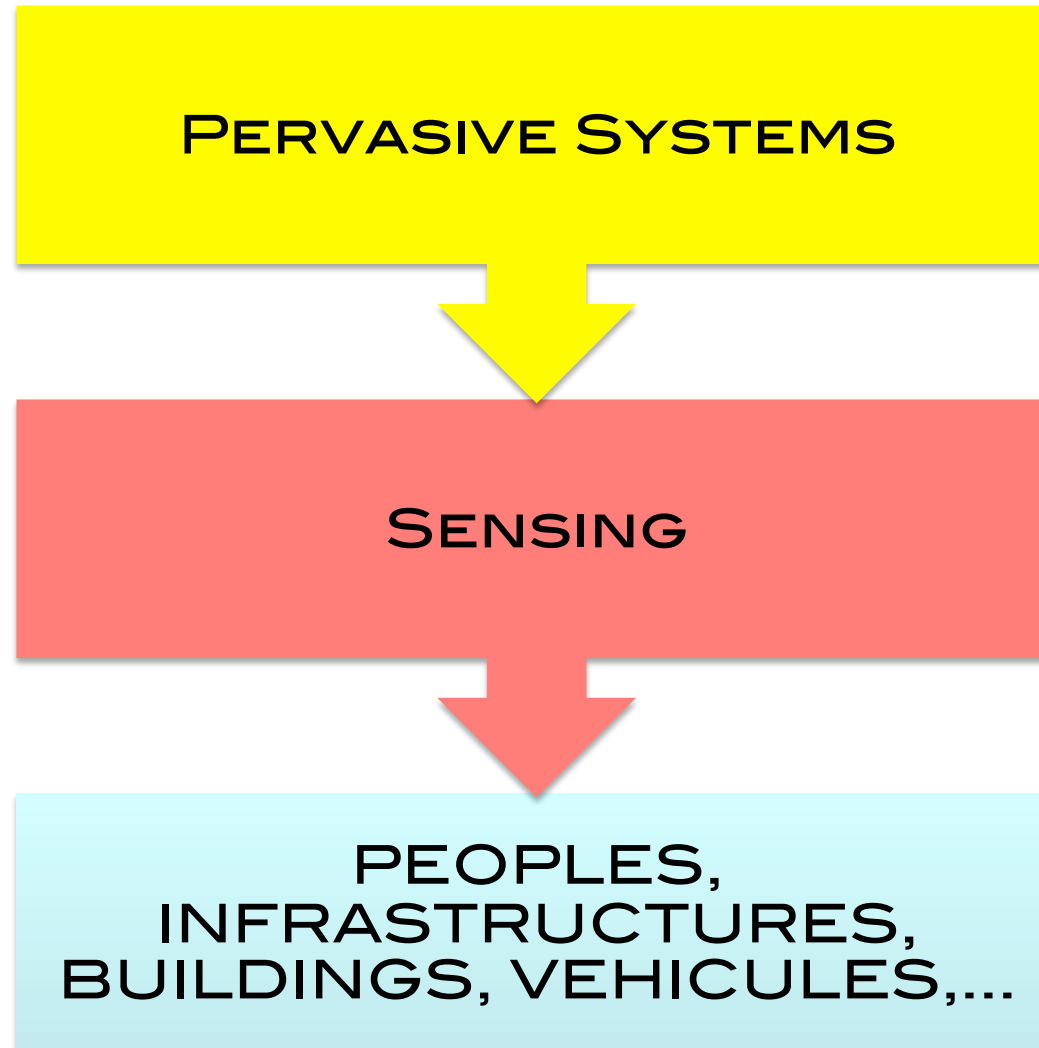

+ ...TO CONTROLLED SYSTEMS.

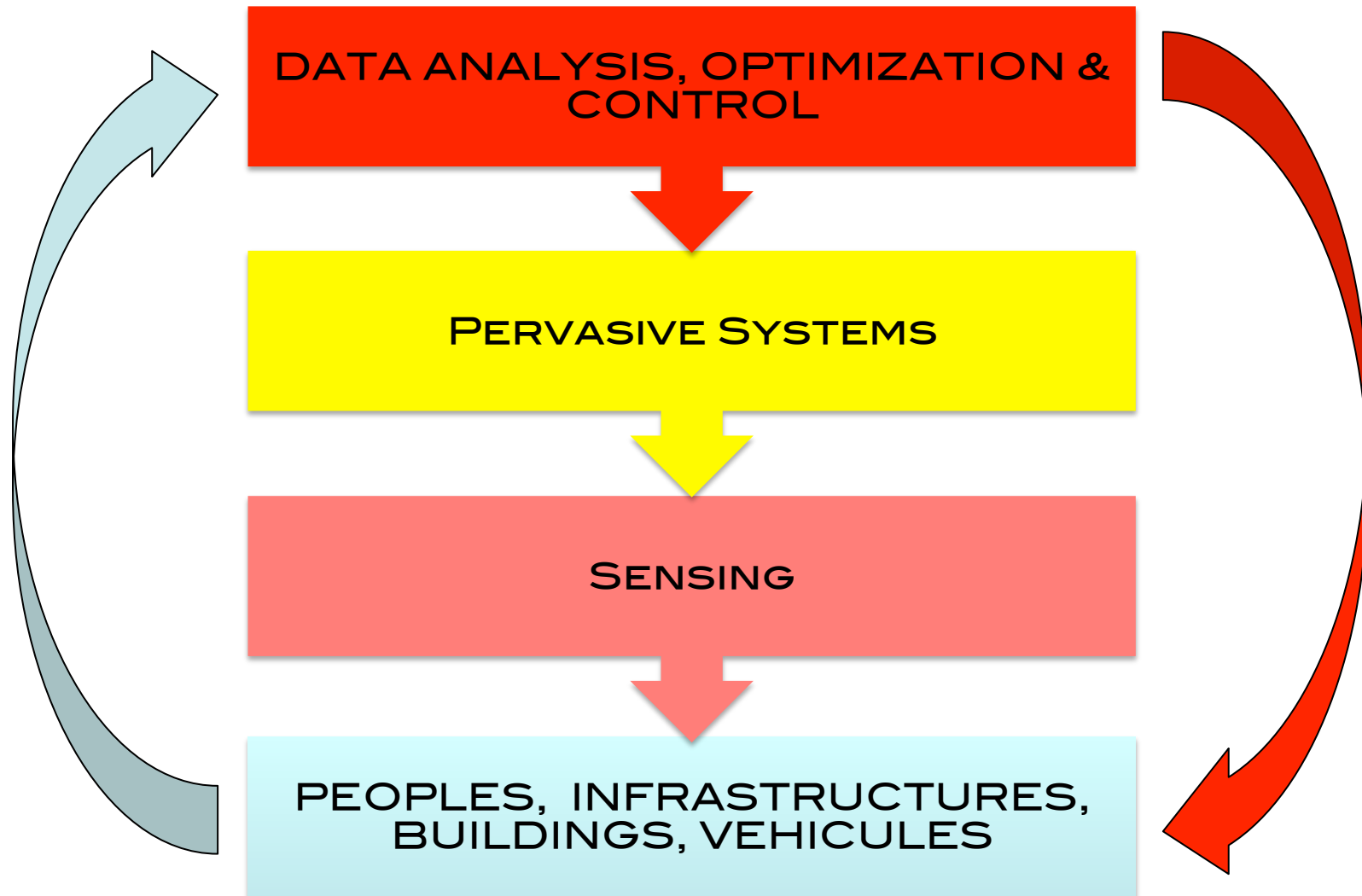

+ EX: SMART ELECTRICITY NETWORKS

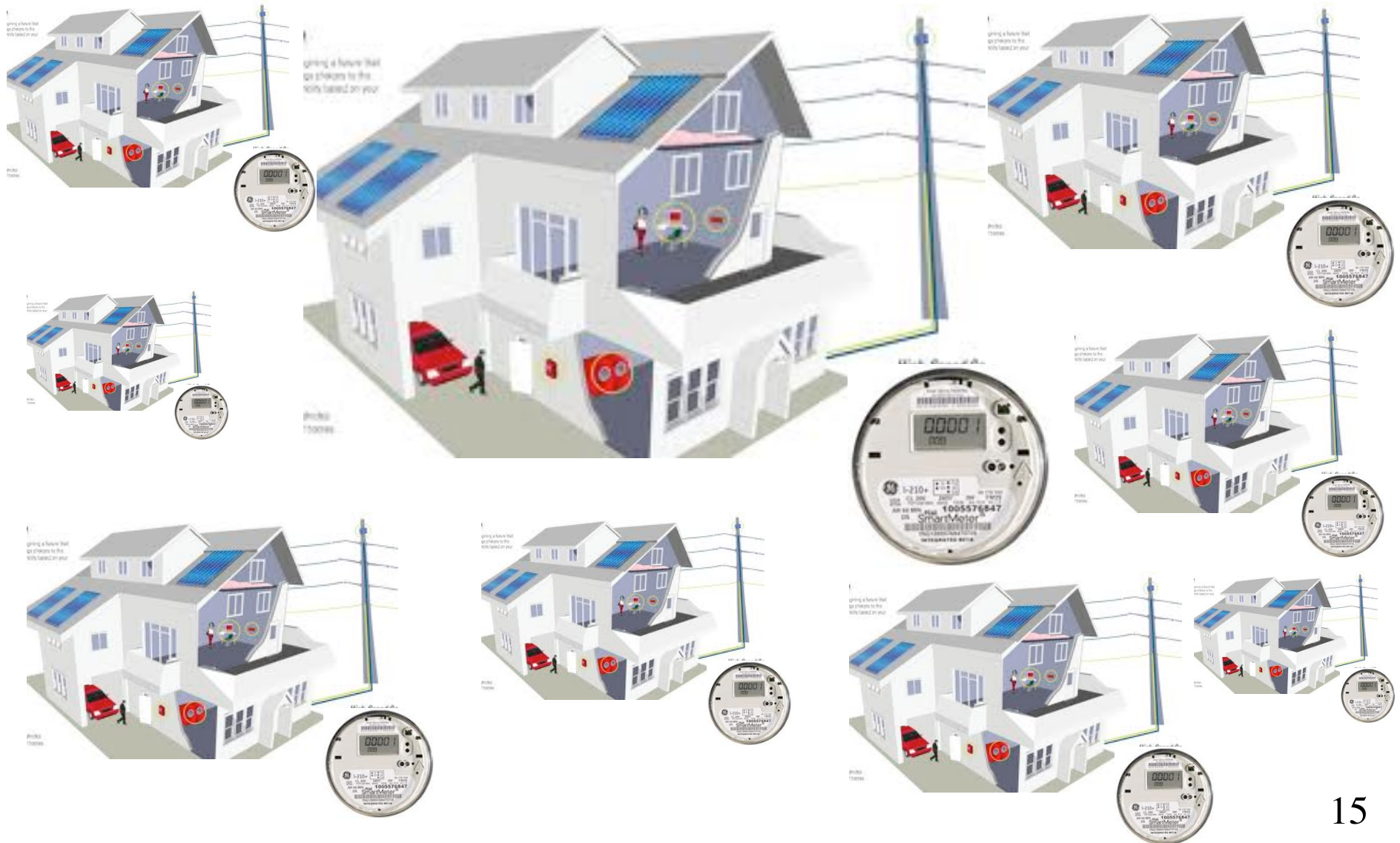
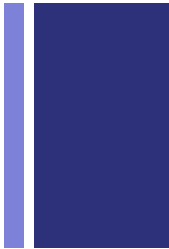

+ EX: SMART ELECTRICITY NETWORKS



Yogesh Simmhan, Baohua Cao, Michail Giakkoupis, and Viktor K. Prasanna. **Adaptive rate stream processing for smart grid applications on clouds**. In Proceedings of the 2nd ACM international workshop on Scientific cloud computing (ScienceCloud '11).

+ MONITORING/ SURVEILLANCE

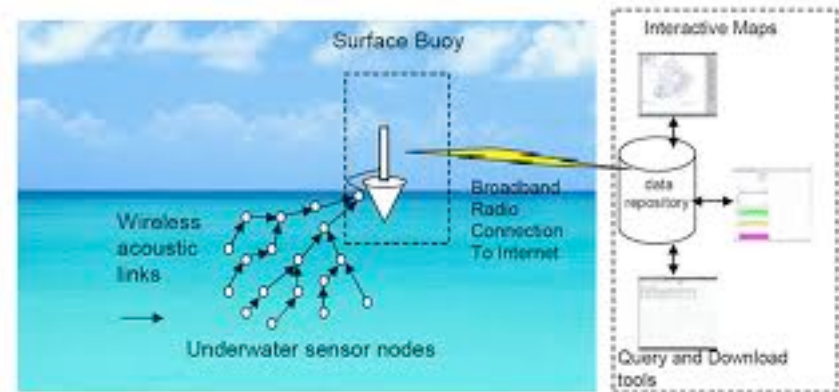

+ WIRELESS AUTONOMOUS SENSORS

- IN GENERAL: LOW COST, LOW POWER (THE BATTERY MAY NOT BE REPLACEABLE), SMALL SIZE, PRONE TO FAILURE, POSSIBLY DISPOSABLE
- ROLE: SENSING, DATA PROCESSING, COMMUNICATION

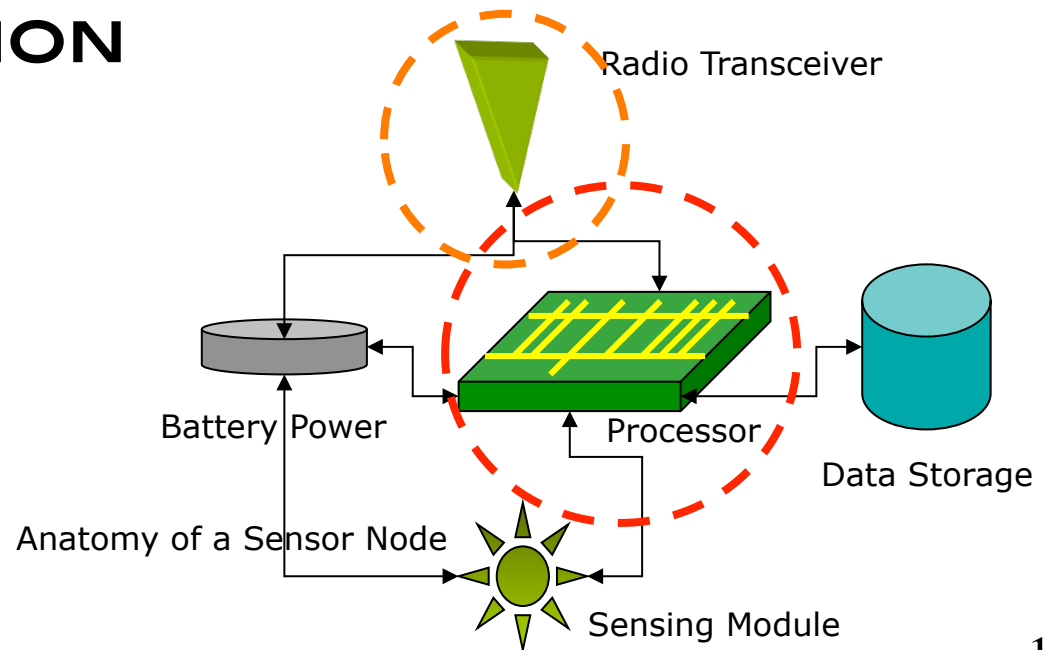
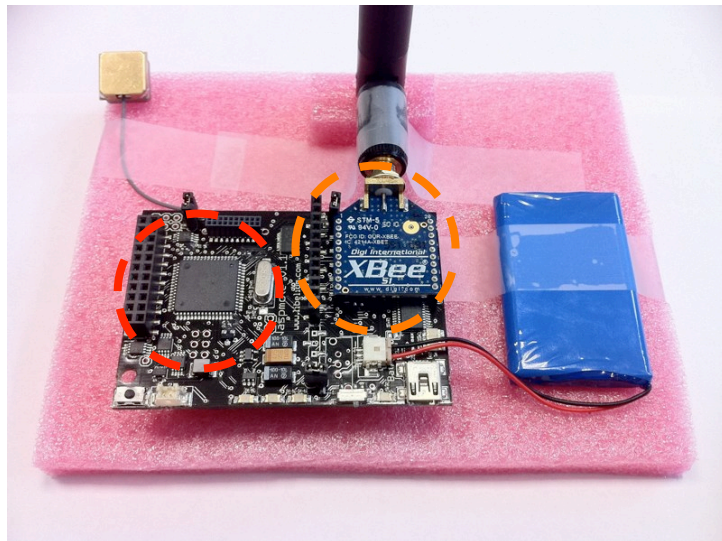



BERKELEY MOTES (CONTD.)



- ❑ EACH MOTE HAS TWO SEPARATE BOARDS
 - ❑ A MAIN CPU BOARD WITH RADIO COMMUNICATION CIRCUITRY
 - ❑ A SECONDARY BOARD WITH SENSING CIRCUITRY
- ❑ DECOUPLES SENSING HARDWARE FROM COMMUNICATION HARDWARE
- ❑ ALLOWS FOR CUSTOMIZATION SINCE APPLICATION SPECIFIC SENSOR HARDWARE CAN BE PLUGGED-ON TO THE MAIN BOARD

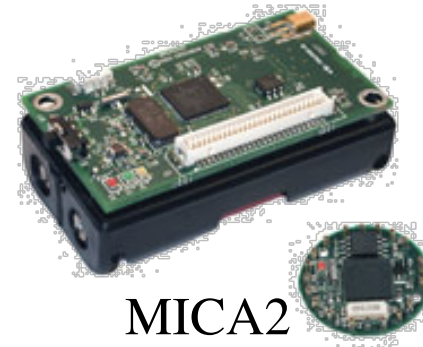

MICA2



MICAz



Imote2

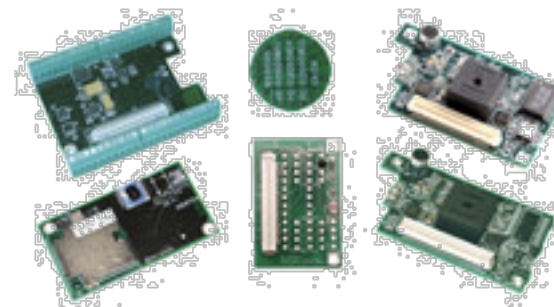

Sensing boards

+ CROSSBOW MOTES OF OUR TESTBED



iMote2

MICAz

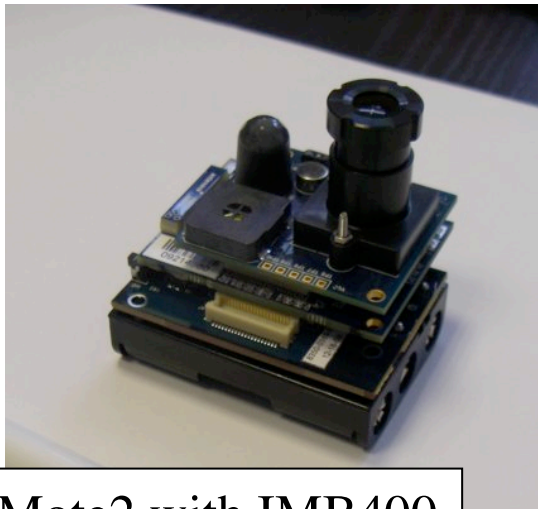
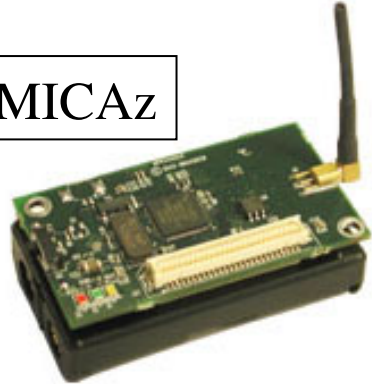

iMote2 with IMB400
multimedia board

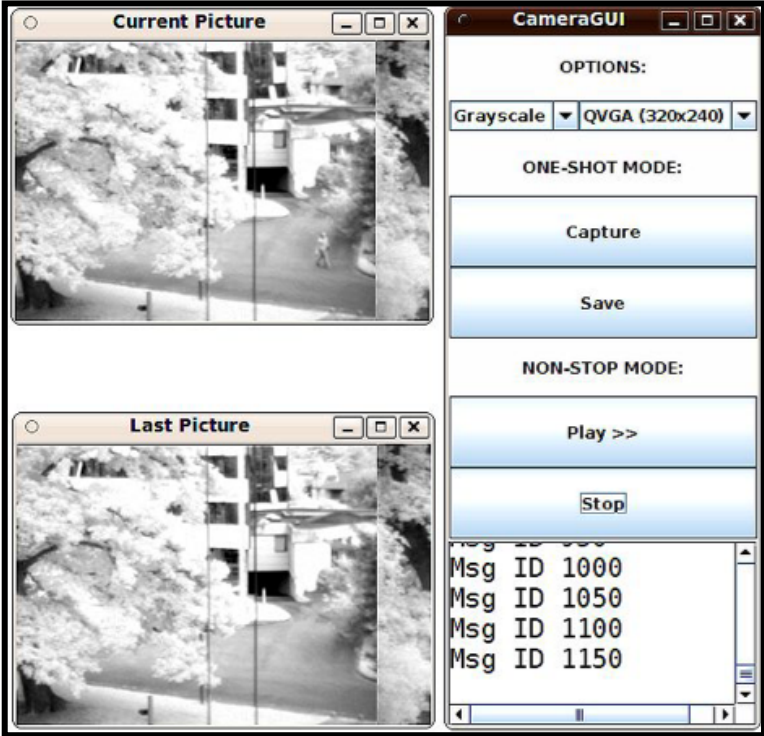

+ SEARCH&RESCUE, SECURITY



Imote2

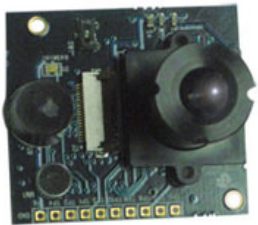

Multimedia
board

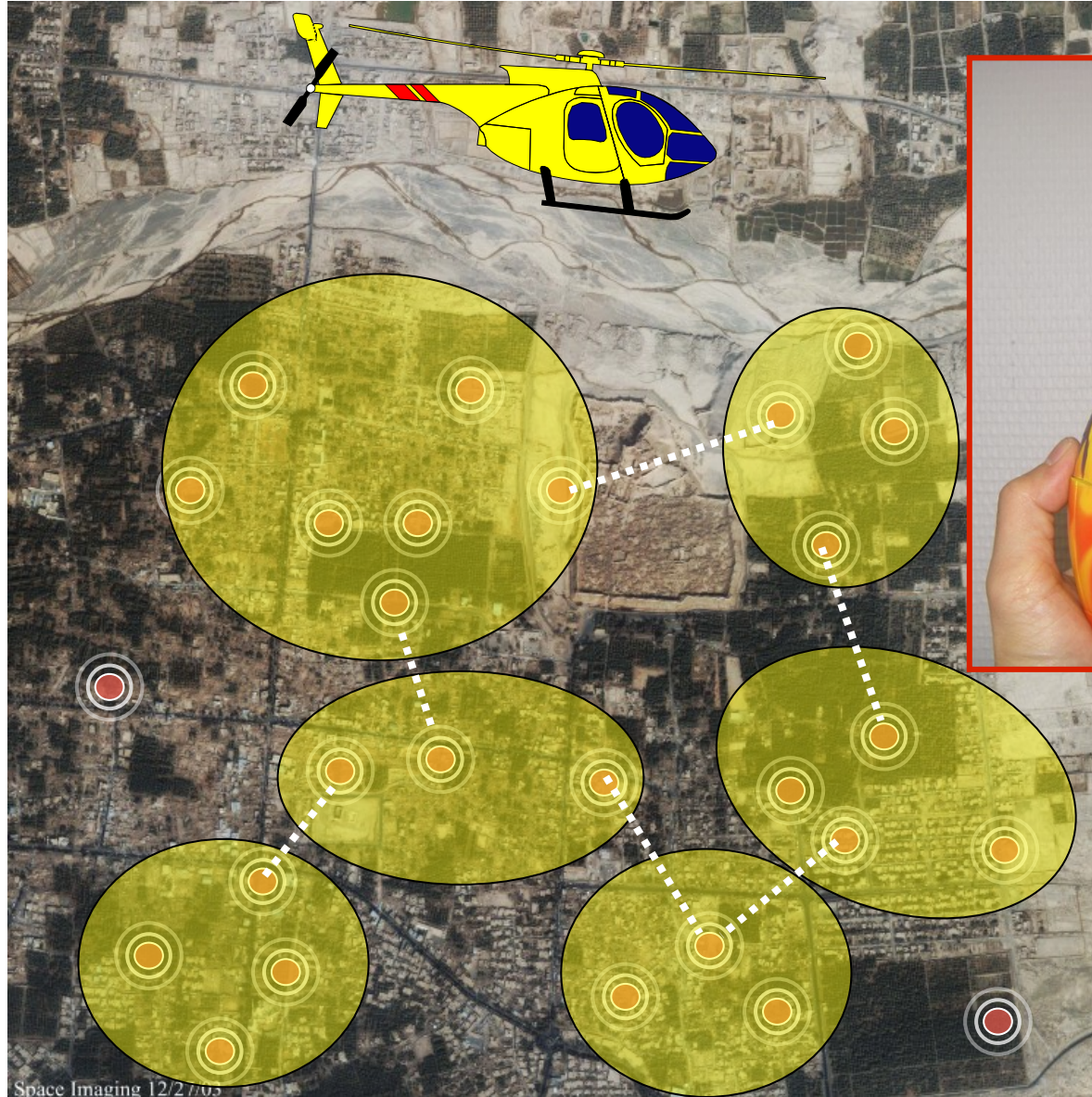



- ❑ ATMEGA1281 MICROCONTROLLER
- ❑ 8K RAM & 1G SD CARD.
- ❑ 2.4GHZ IEEE 802.15.4 COMPATIBLE. RF AND GSM/GPRS



Gases



- Carbon Monoxide – CO
- Carbon Dioxide – CO2
- Oxygen – O2
- Methane – CH4
- Hydrogen – H2
- Ammonia – NH3
- Isobutane – C4H10
- Ethanol – CH3CH2OH
- Toluene – C6H5CH3
- Hydrogen Sulfide – H2S
- Nitrogen Dioxide – NO2
- Temperature
- Humidity

Events



- Pressure/Weight
- Bend
- Vibration
- Impact
- Hall Effect
- Tilt
- Temperature (+/-)
- Liquid Presence
- Liquid Level
- Luminosity
- Presence (PIR)
- Stretch

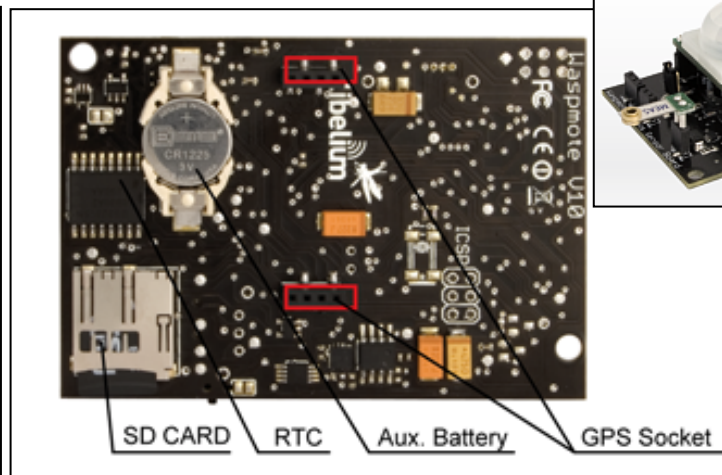
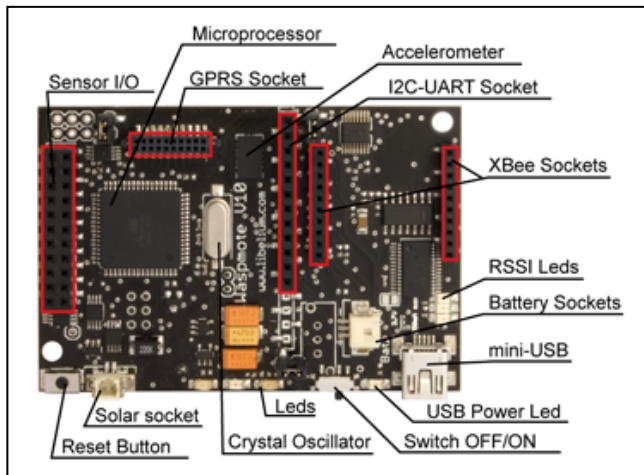



LIBELIUM WASPMOTE (1)

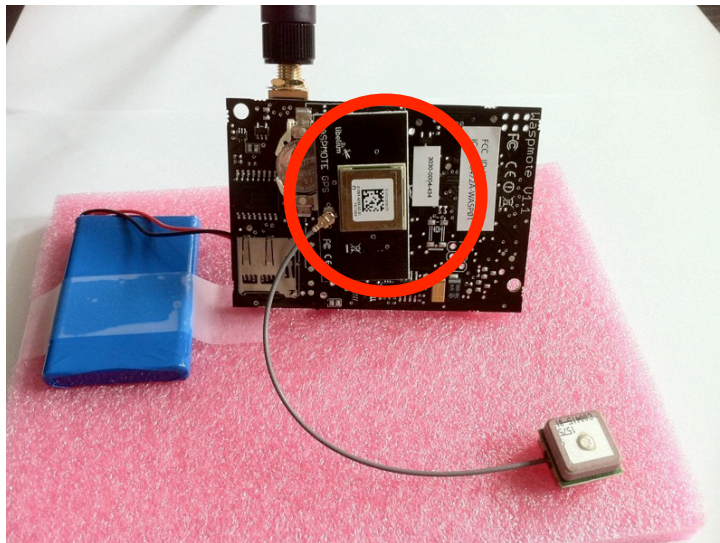
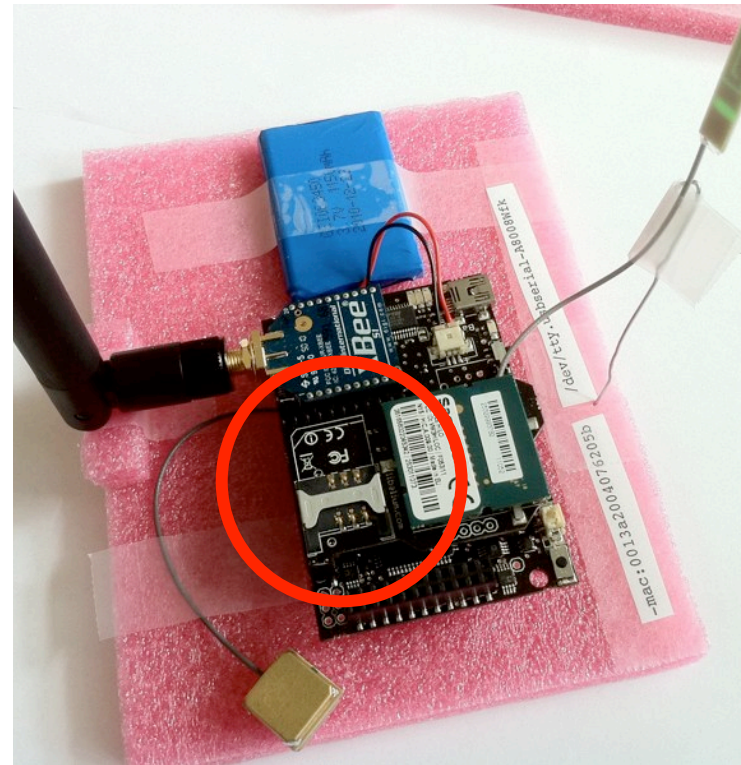
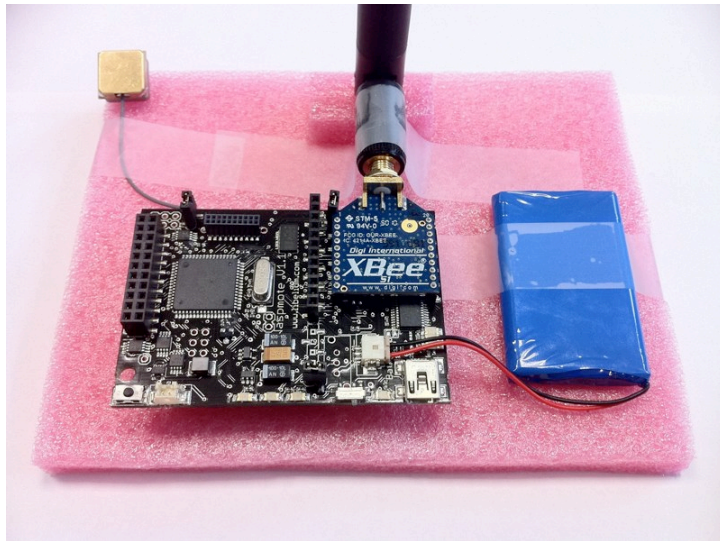
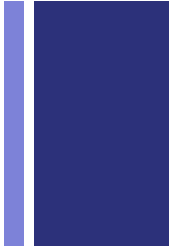



ADVANCED CONNECTIVITY

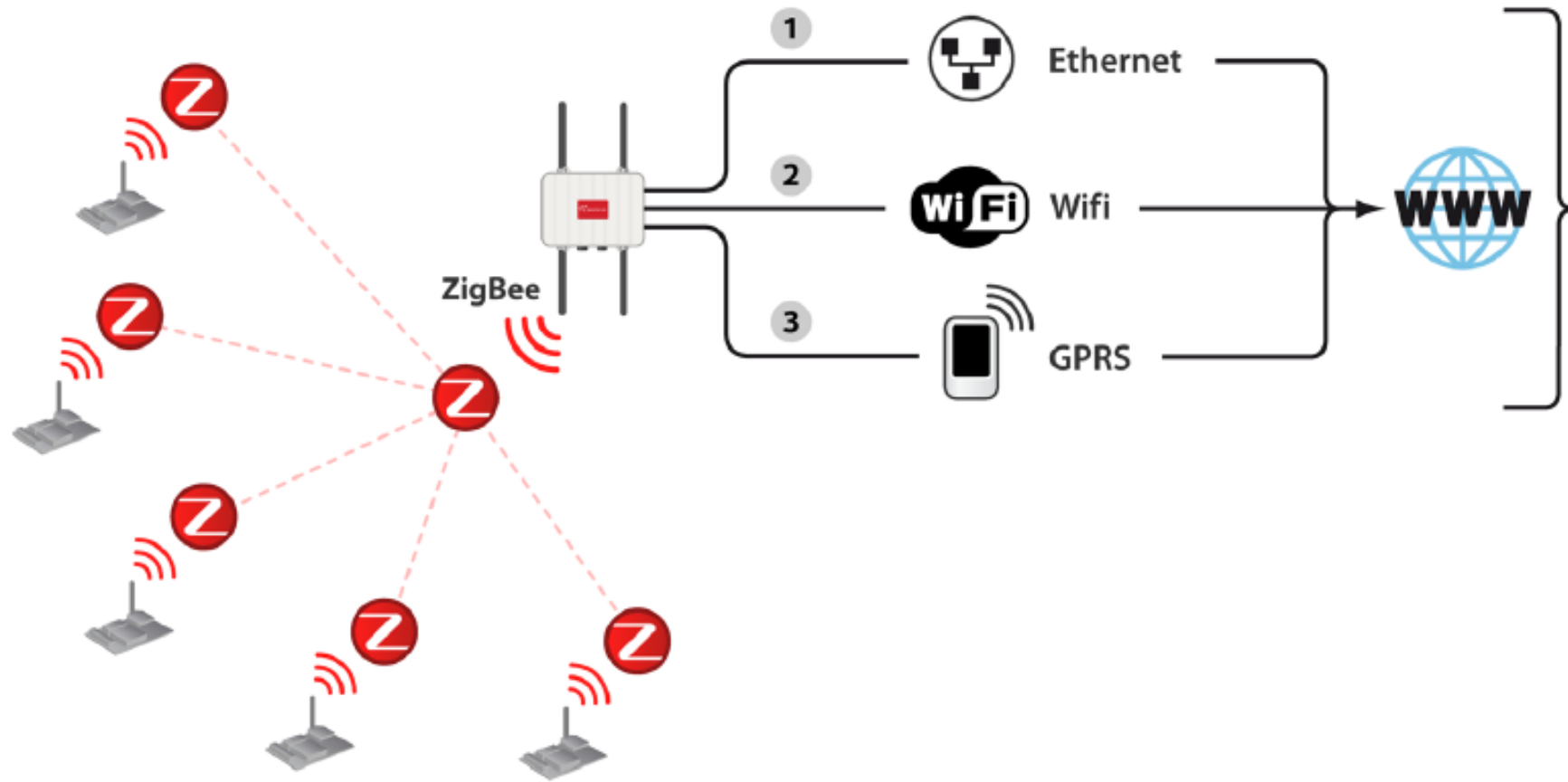

+ ADVANCED DATABASE FEATURES

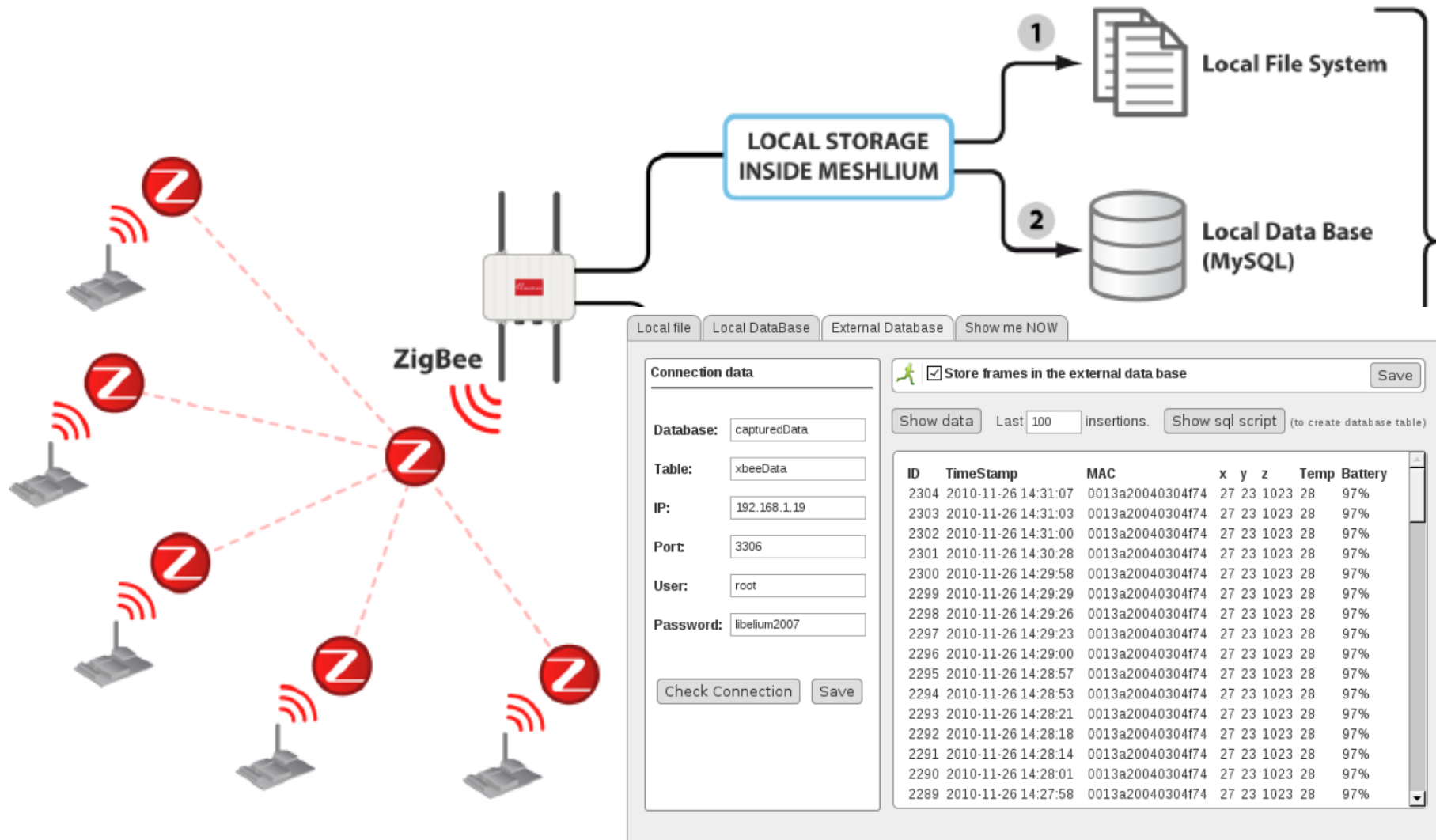



THE FULL TESTBED

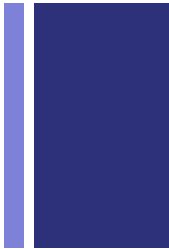



AIR QUALITY MONITORING





SPECIFIC APPLICATIONS

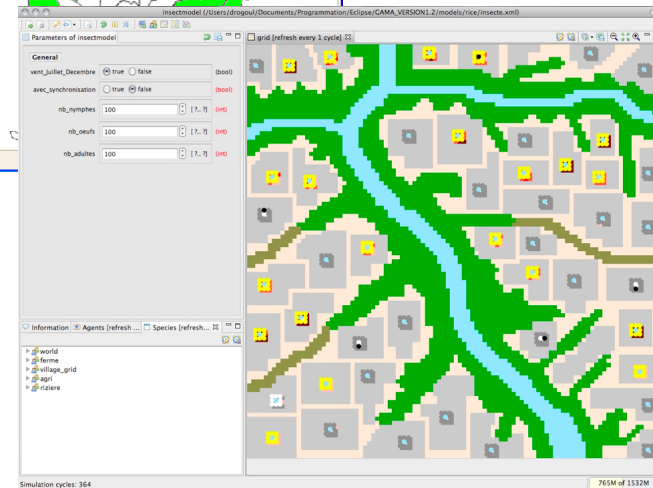
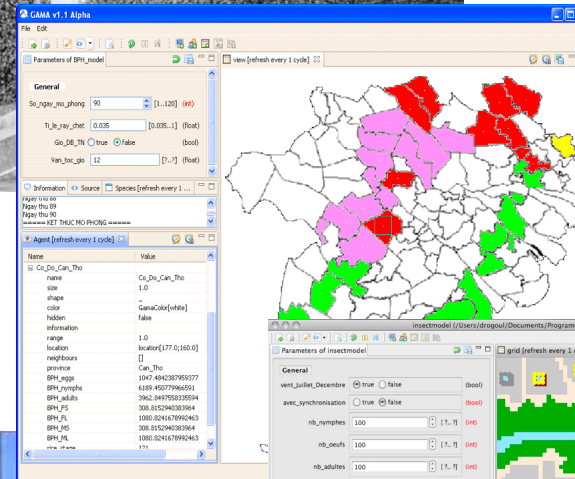
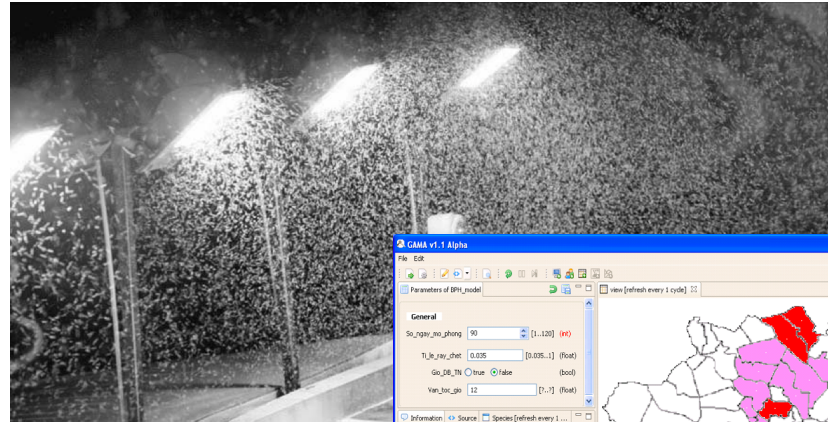



TOWARDS GLOBAL SENSING

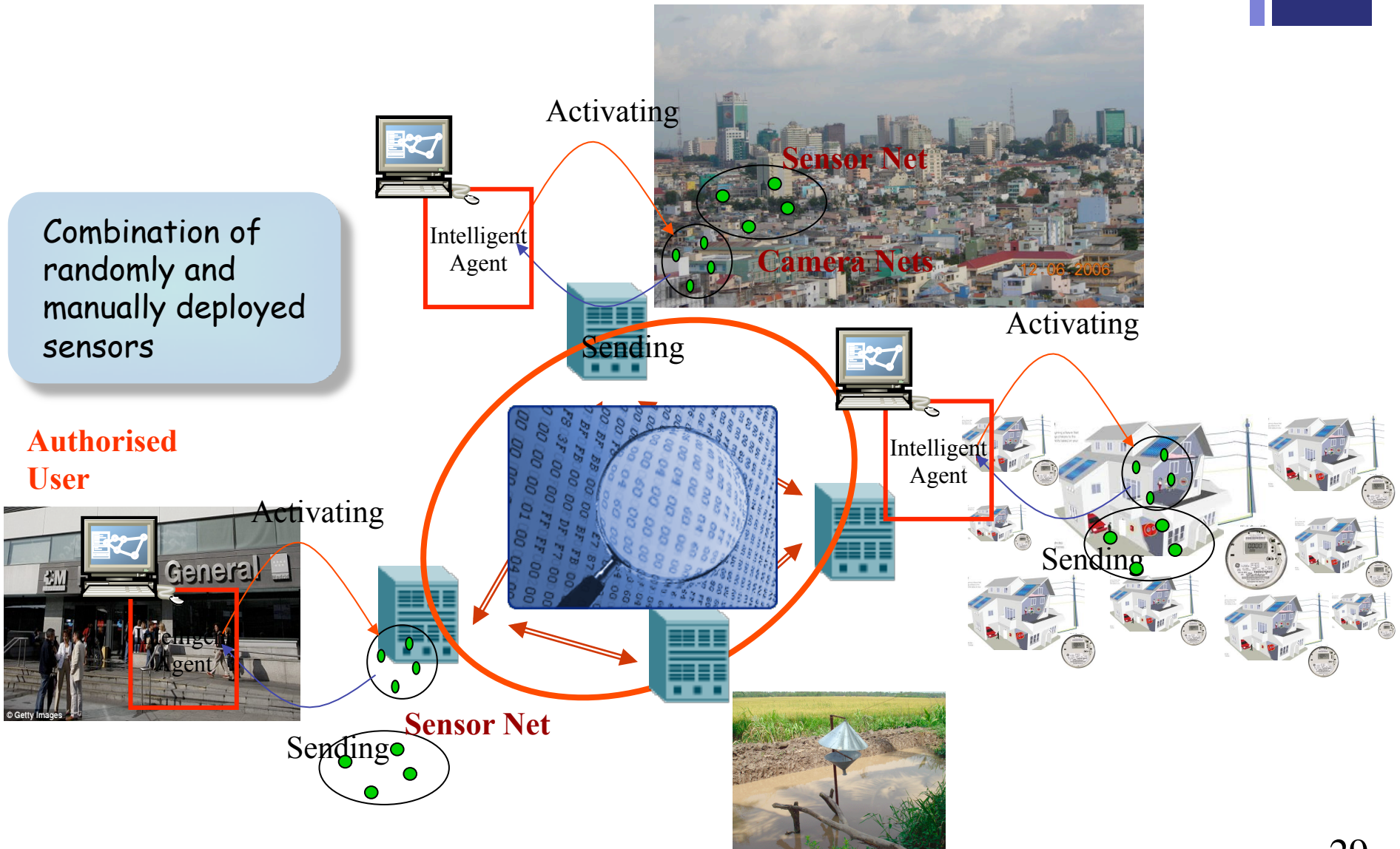



WHERE CLOUDS COME IN!

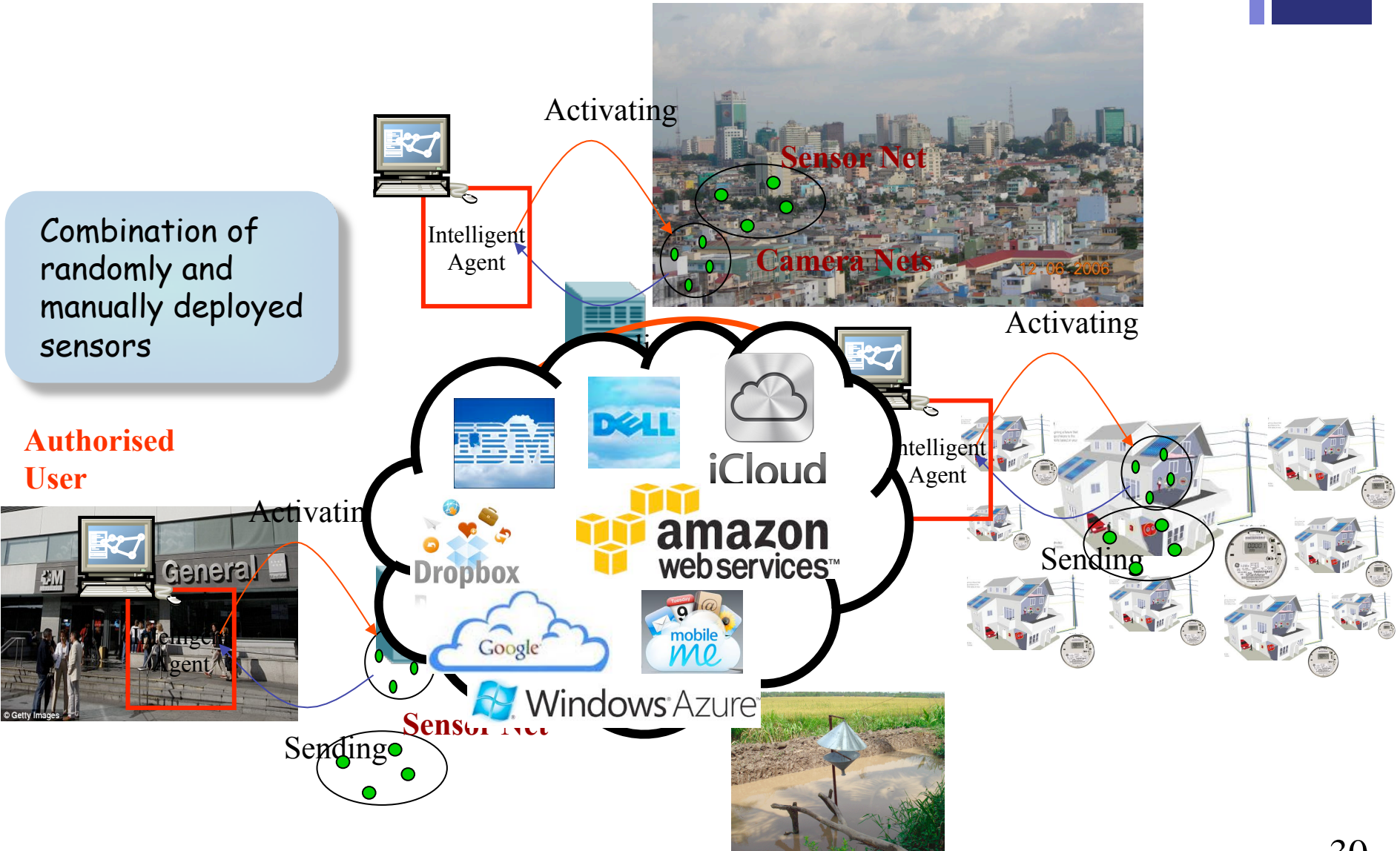



CLOUD FOR EVERY APPS!



□ THE SHARED CLOUD ASSUMPTION



Many users, with various profile and different needs!



VARIOUS PROFILES, DIFFERENT NEEDS, BUT SAME EXPECTATIONS!

« QoS »

Economic Elements:
Pay-as-you-go, pay-as-you-grow, no CAPEX.

Architectural Elements:
Simple, abstract environment for development.

Strategic Elements:
Focus on your core business, leave the rest to someone else.

Concept: MWD Advisors, www.mwdadvisors.com

+ WHAT IS QUALITY OF SERVICE?



- ❑ QUALITY OF SERVICE IS THE ABILITY TO PROVIDE DIFFERENT PRIORITY TO DIFFERENT APPLICATIONS, USERS, OR DATA FLOWS, OR TO GUARANTEE A CERTAIN LEVEL OF PERFORMANCE
- ❑ QOS CRITERIA ARE NUMEROUS AND IS HIGHLY DEPENDANT OF THE APP.
 - ❑ THROUGHPUT, DELAY, JITTER, LOSS RATE, AVAILABILITY, UPTIME, ...
- ❑ ... OR DRIVEN BY THE END-USER
 - ❑ IMAGE RESOLUTION, SOUND QUALITY, APPROPRIATE LANGUAGE, ...



QoS, SLA (1)



From V.D. Cunsolo et al. « Open and Interoperable Clouds: The Cloud@Home Way », chap. 6. In « Cloud Computing: Principles, Systems and Applications », N Antonopoulos & L. Gillam (eds), Springer Computer Communications and Networks series, 2010.

« Business models – for selling Cloud computing, it is mandatory to provide QoS and SLA management for both commercial and open-volunteer Clouds (traditionally best effort) to discriminate among the applications to be run. »



QoS, SLA (2)



*From Vladimir Stantchev and Christian Schröpfer,
« Negotiating and Enforcing QoS and SLAs in Grid and Cloud
Computing ». In Advances in Grid and Pervasive Computing,
Lecture Notes in Computer Science, 2009, Volume 5529/2009.*

« Emerging grid computing infrastructures such as cloud computing can only become viable alternatives for the enterprise if they can provide stable service levels for business processes and SLA-based costing. »

+ QoS, SLA (3)

S. Bose et al. « SLA MANAGEMENT IN CLOUD COMPUTING: A SERVICE PROVIDER'S PERSPECTIVE », chap. 16. In « Cloud Computing: principles and paradigms », R. Buya, J. Broberg, A. Goscinski (eds), Wiley.

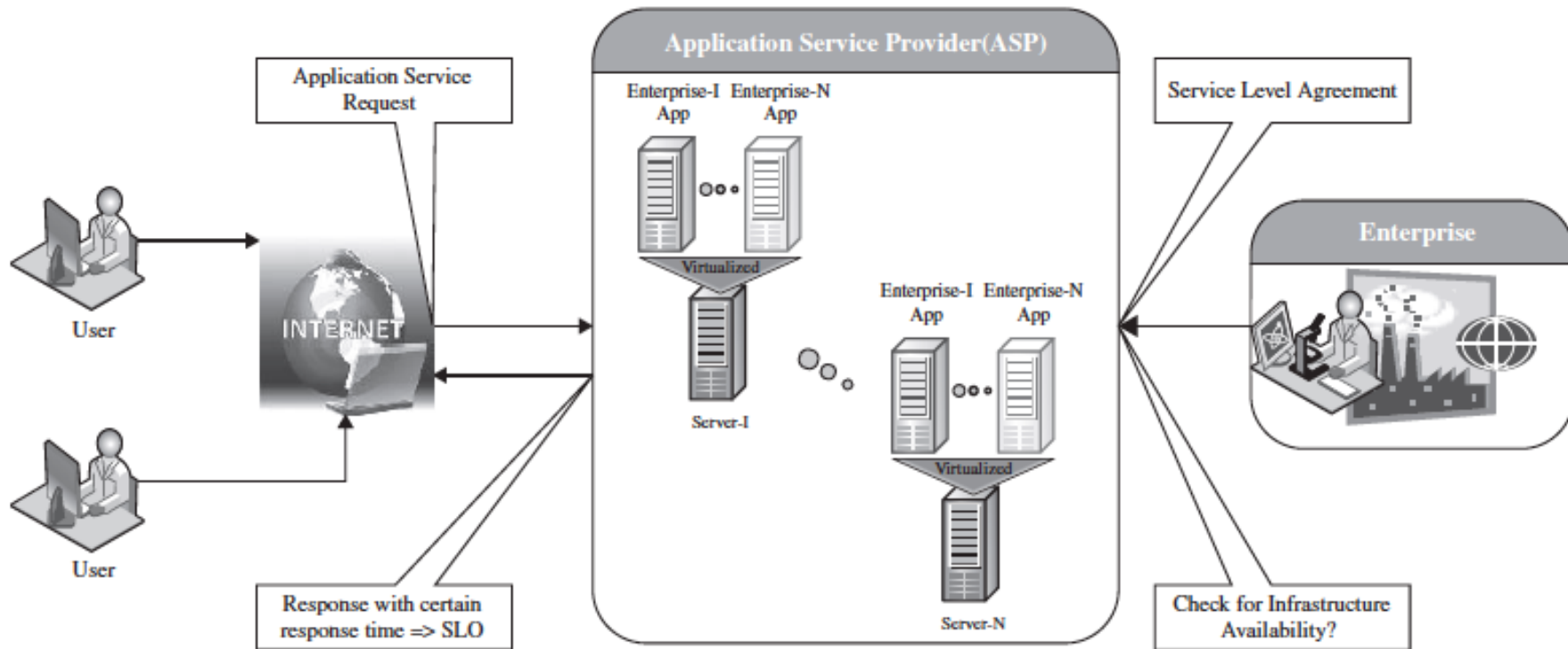
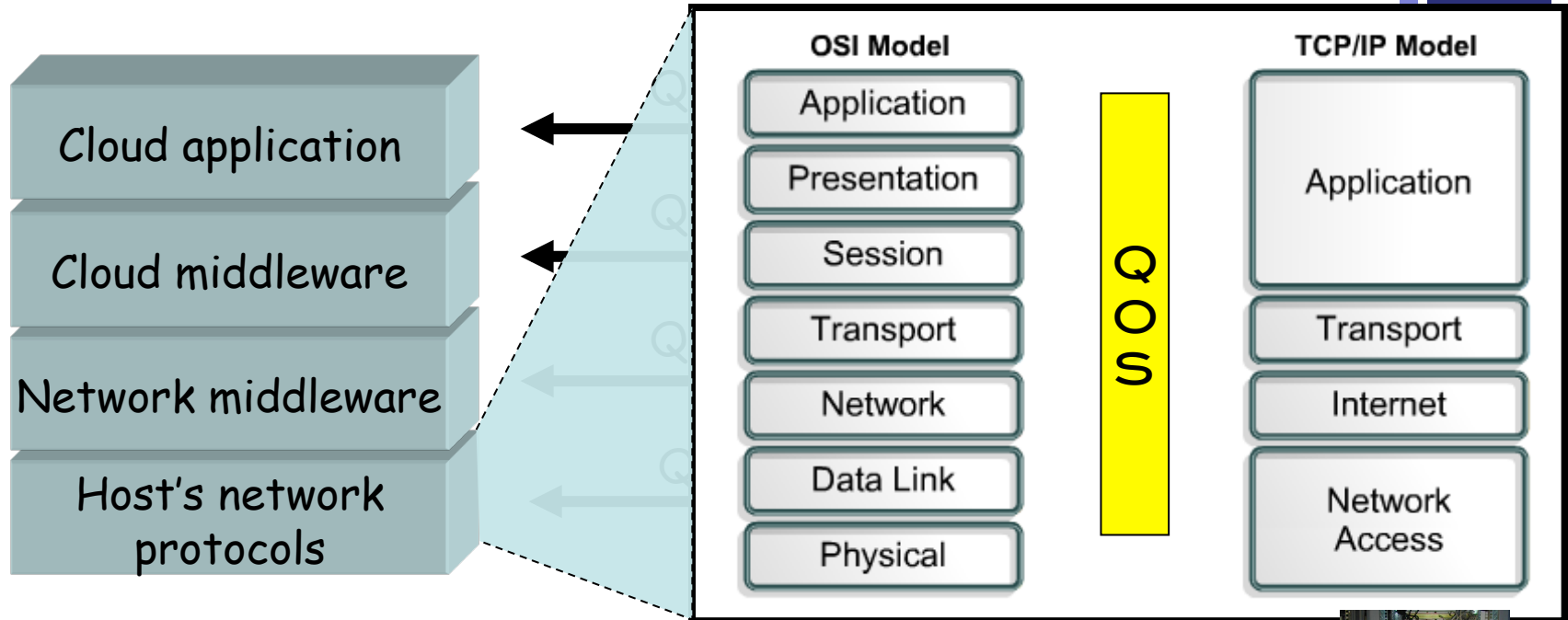

FIGURE 16.4. Shared hosting of applications on virtualized servers within ASP's data centers.



QoS IN A CLOUD



NETWORK QoS

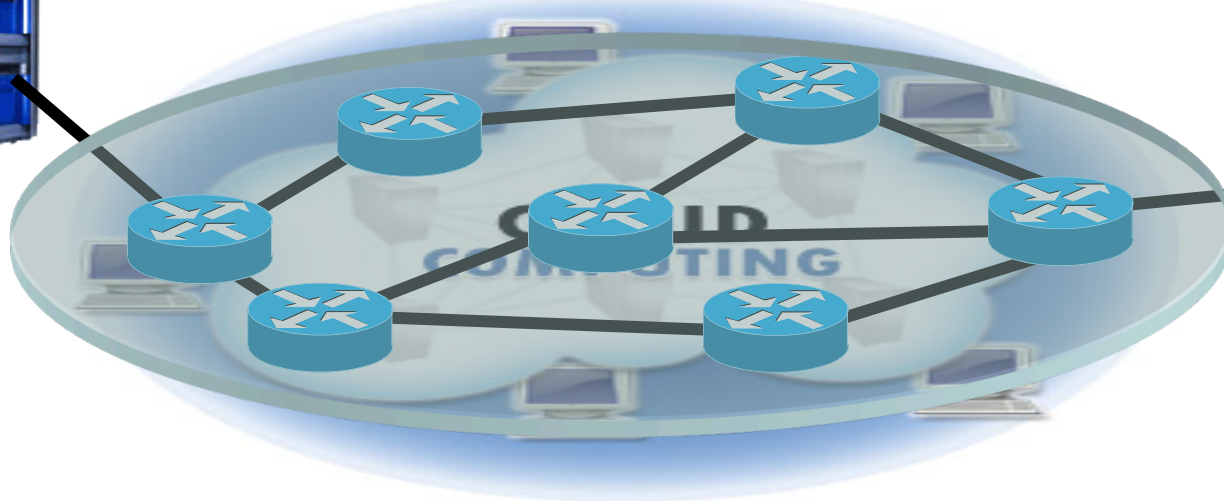

+ QoS: DIFFERENT MEANINGS AT DIFFERENT LAYERS

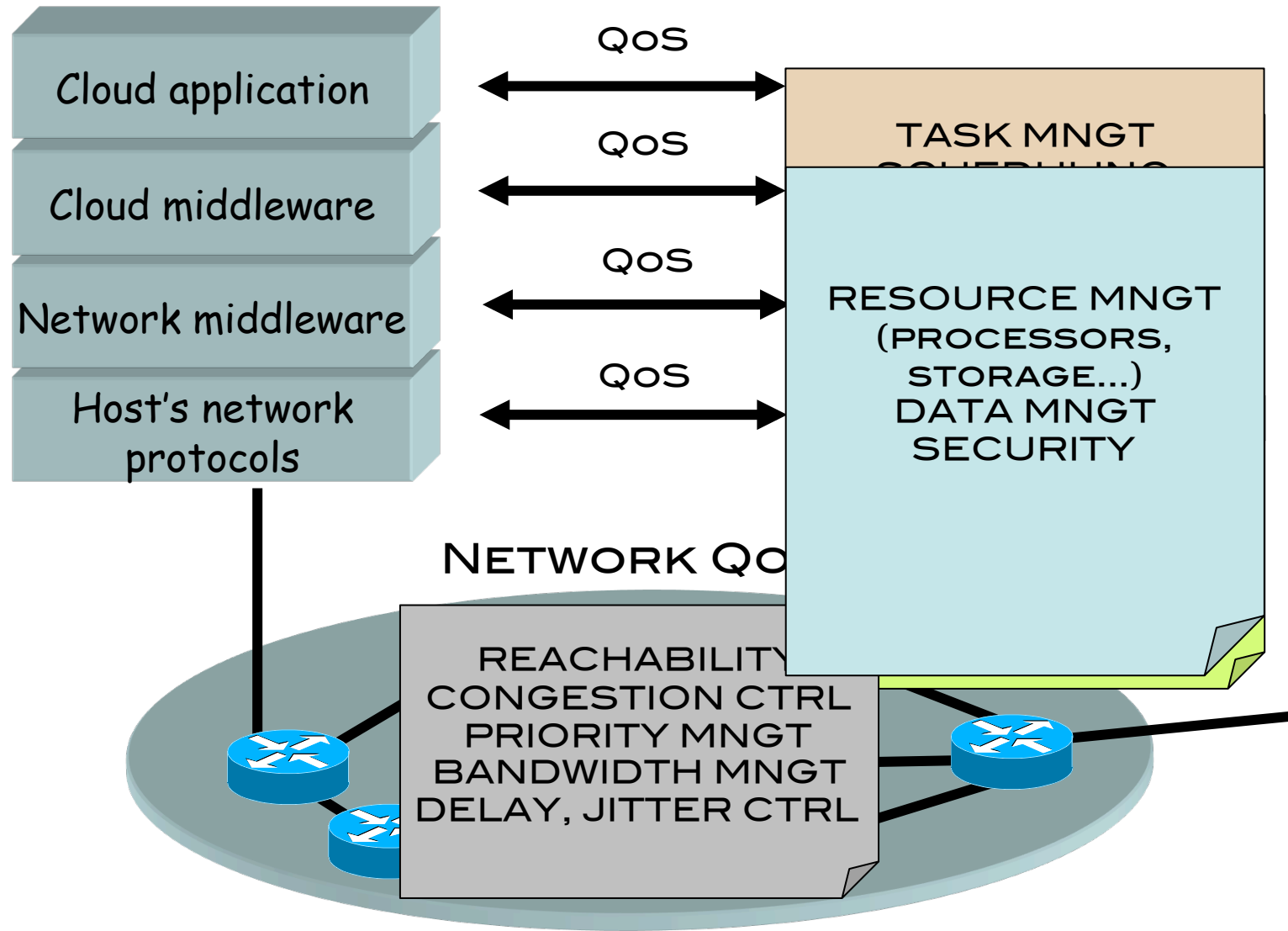

+ 30 YEARS OF INTERNET QoS...

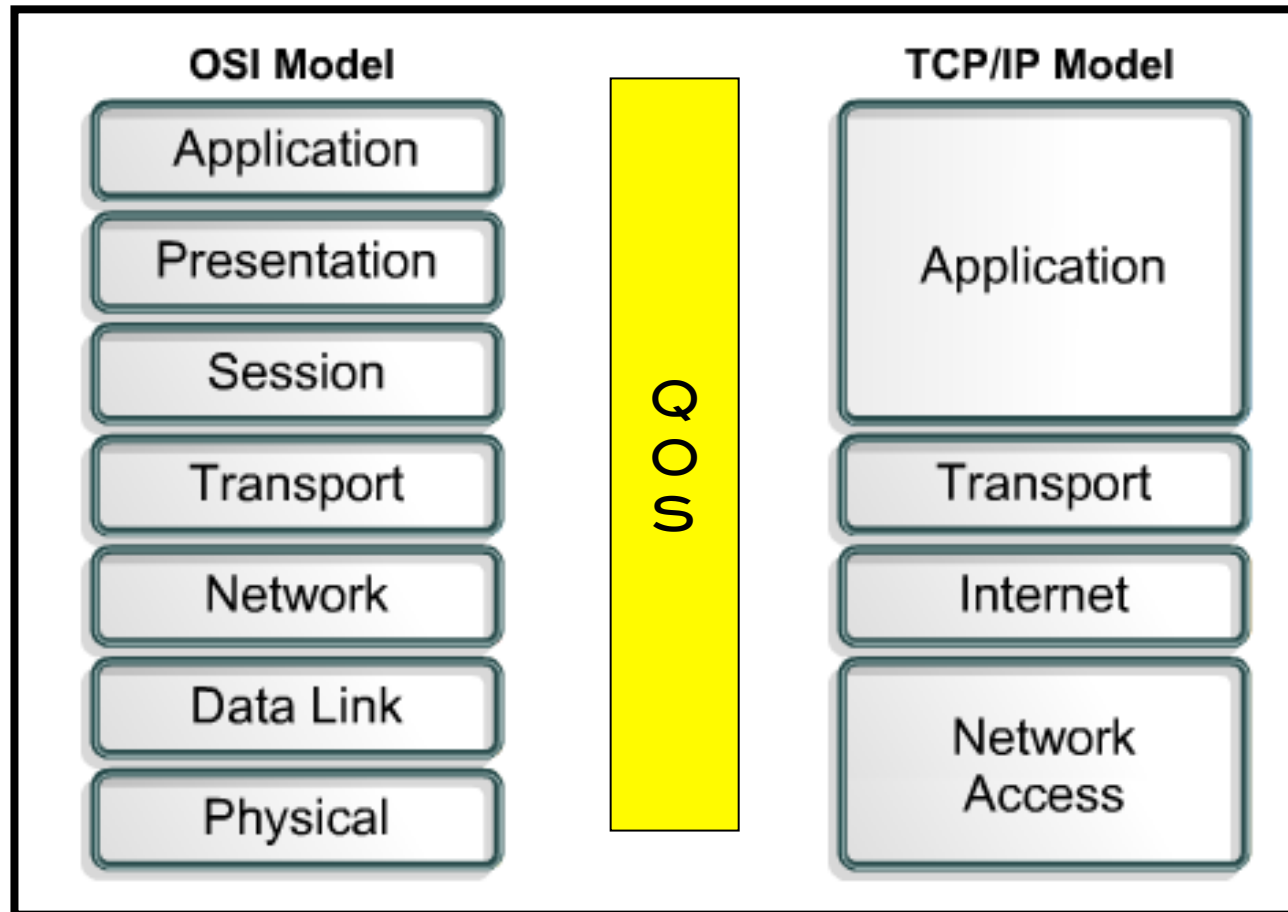

+ ...HAVE SHOWN THE POWER
OF SELFISHNESS!



WHY
SHOULD I
BOTHER
WITH
QOS
WHEN...

...OTHERS
DON'T DO
IT?



CURRENT INTERNET'S QOS



Q

IT WORKS!



SO WHY CHANGE?

+ INTERNET VS CLOUD (COMPUTING)

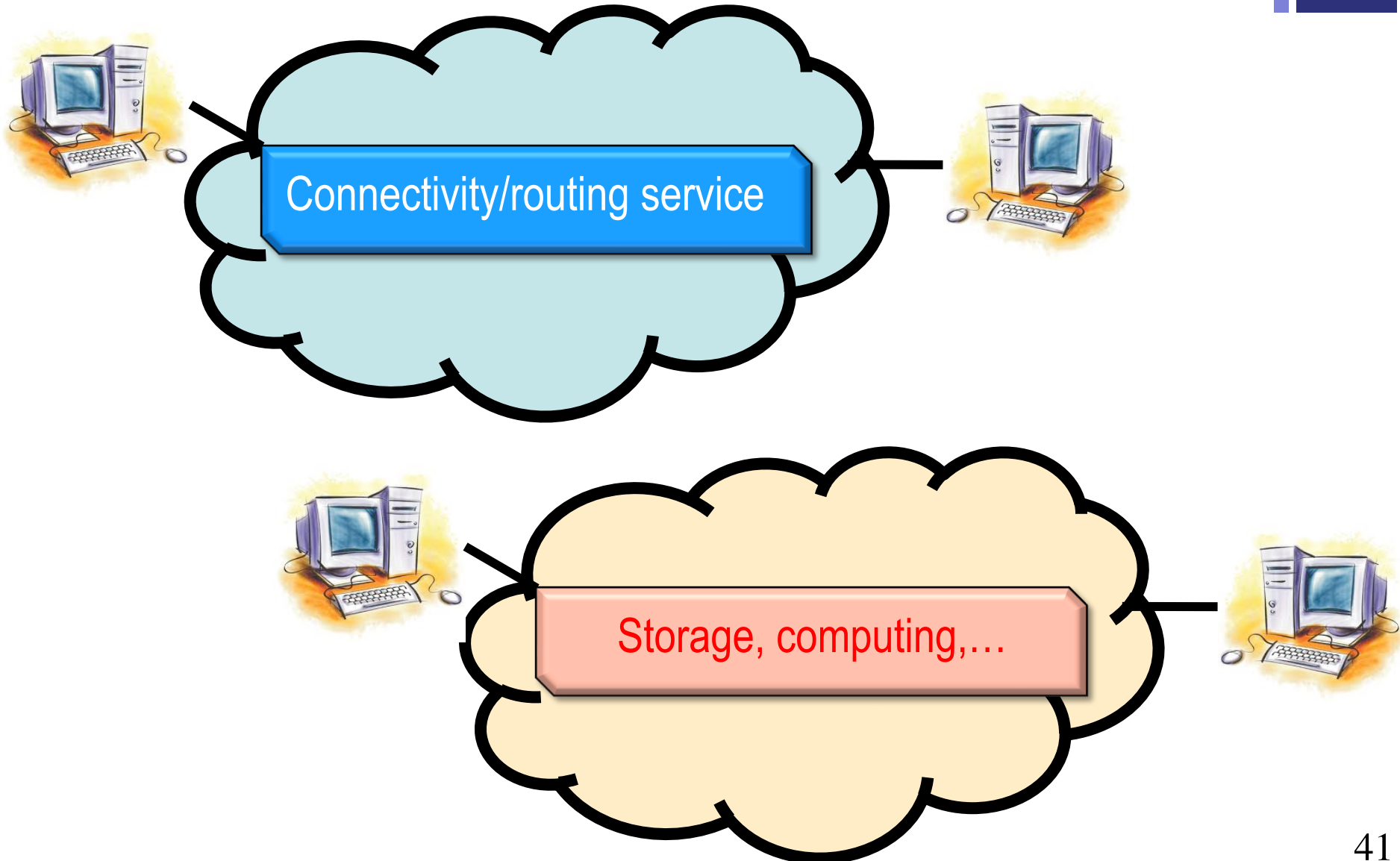



WHEN DISTRIBUTED IS BAD

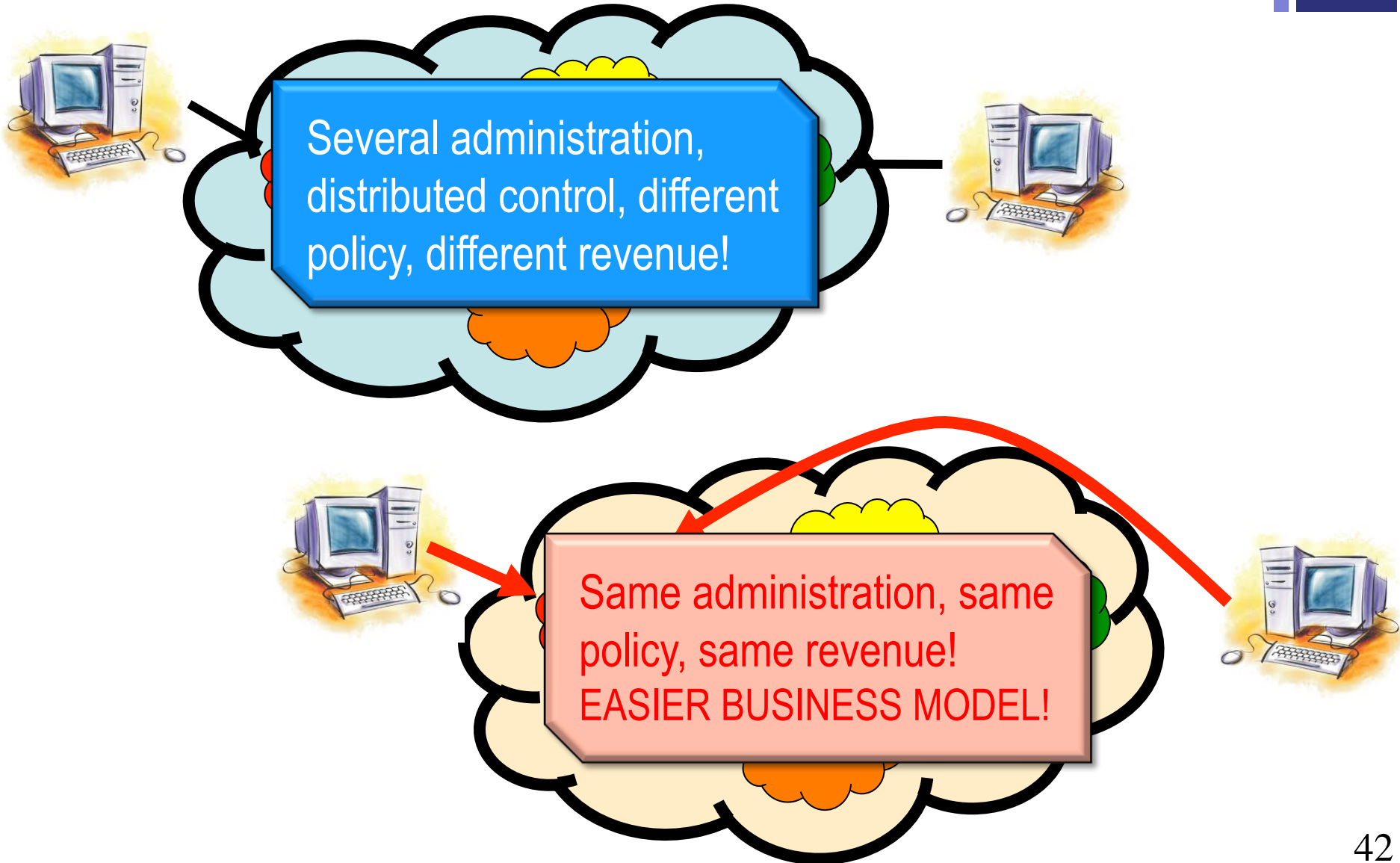

+ WHERE TO PROVIDE QOS IN A CLOUD?

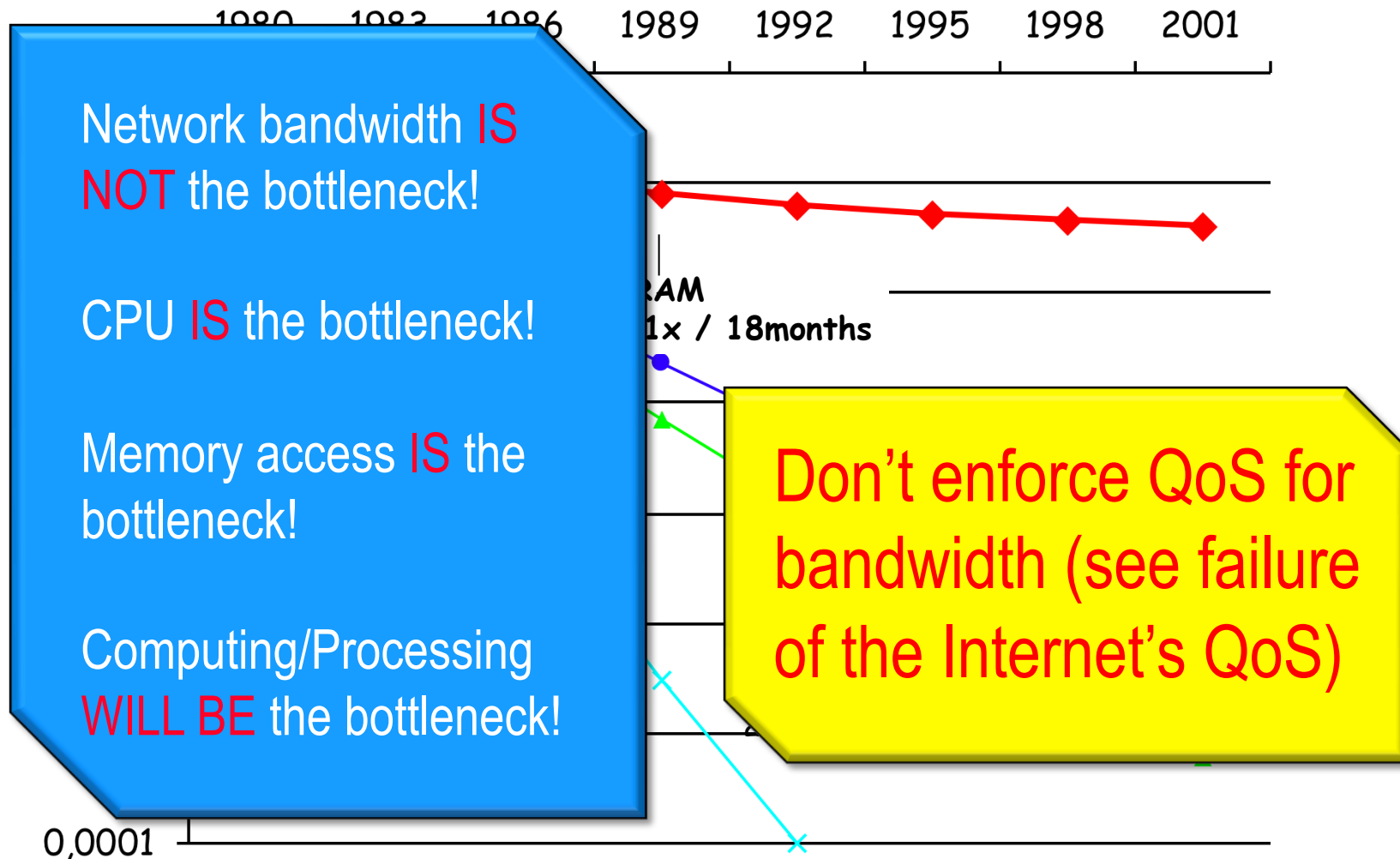

+ HOW TO PROVIDE QOS IN A COMPUTING CLOUD?

- ❑ NO NETWORKING QOS!
- ❑ SCHEDULING, ADMISSION CONTROL, TRAFFIC CONTROL, DYNAMIC RESOURCE PROVISIONING, ...

How to take into account the various application's profiles?
How to protect users from misbehaving applications?
How to handle urgent demands?

Regulate (adapt & control) the data injection rate into the computing resources

+ CLOUD APPLICATION'S PROFILE

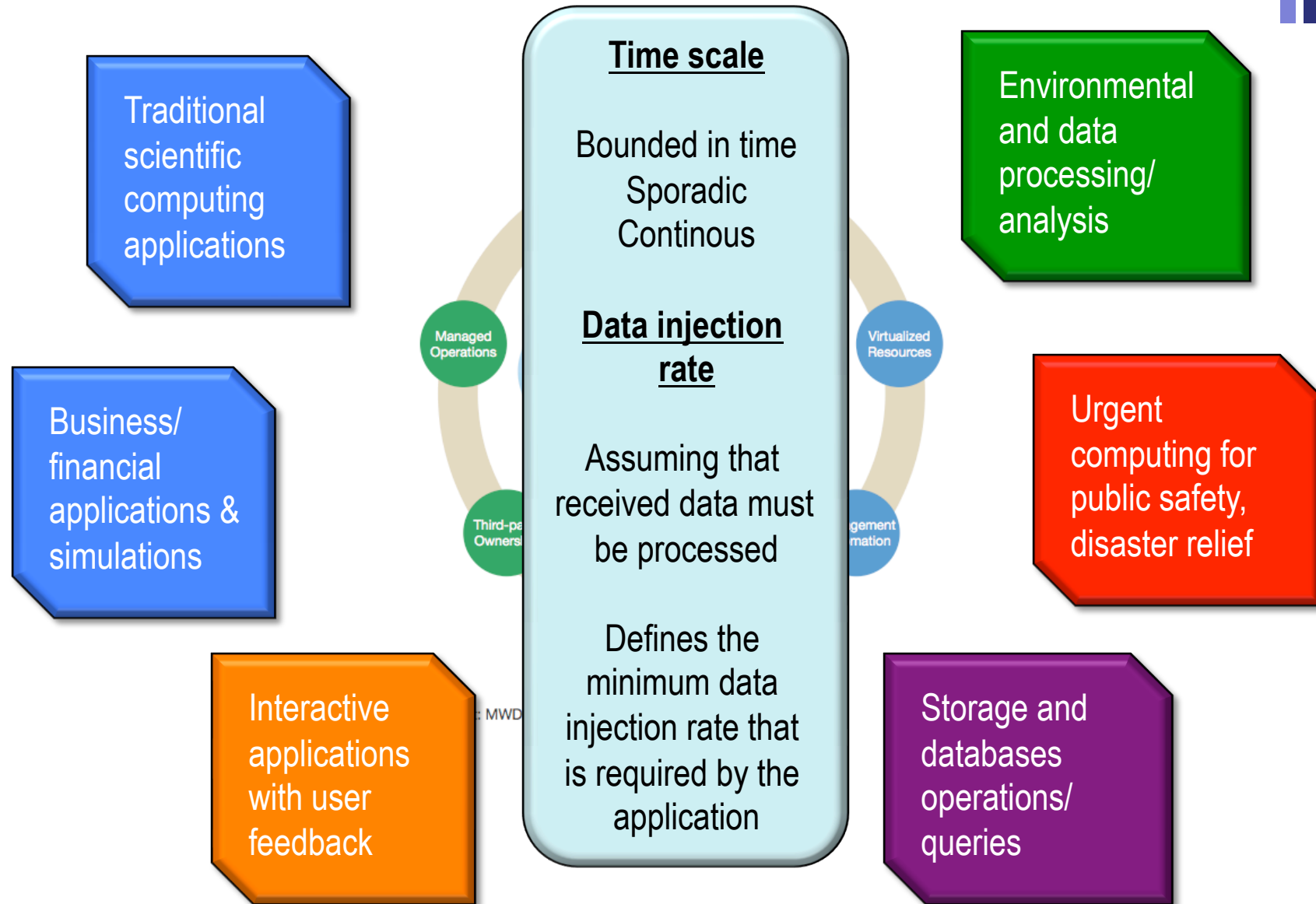



EX: URGENT DISASTER RELIEF



Imote2

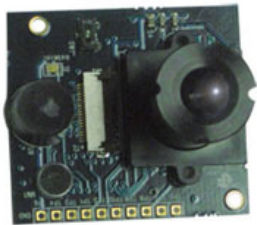

Multimedia board

TIME SCALE

CONTINUOUS

DATA
INJECTION
RATE

MIN=10 FPS

Space Imaging 12/2/05

+ EVERYBODY'S DATA IS IMPORTANT!

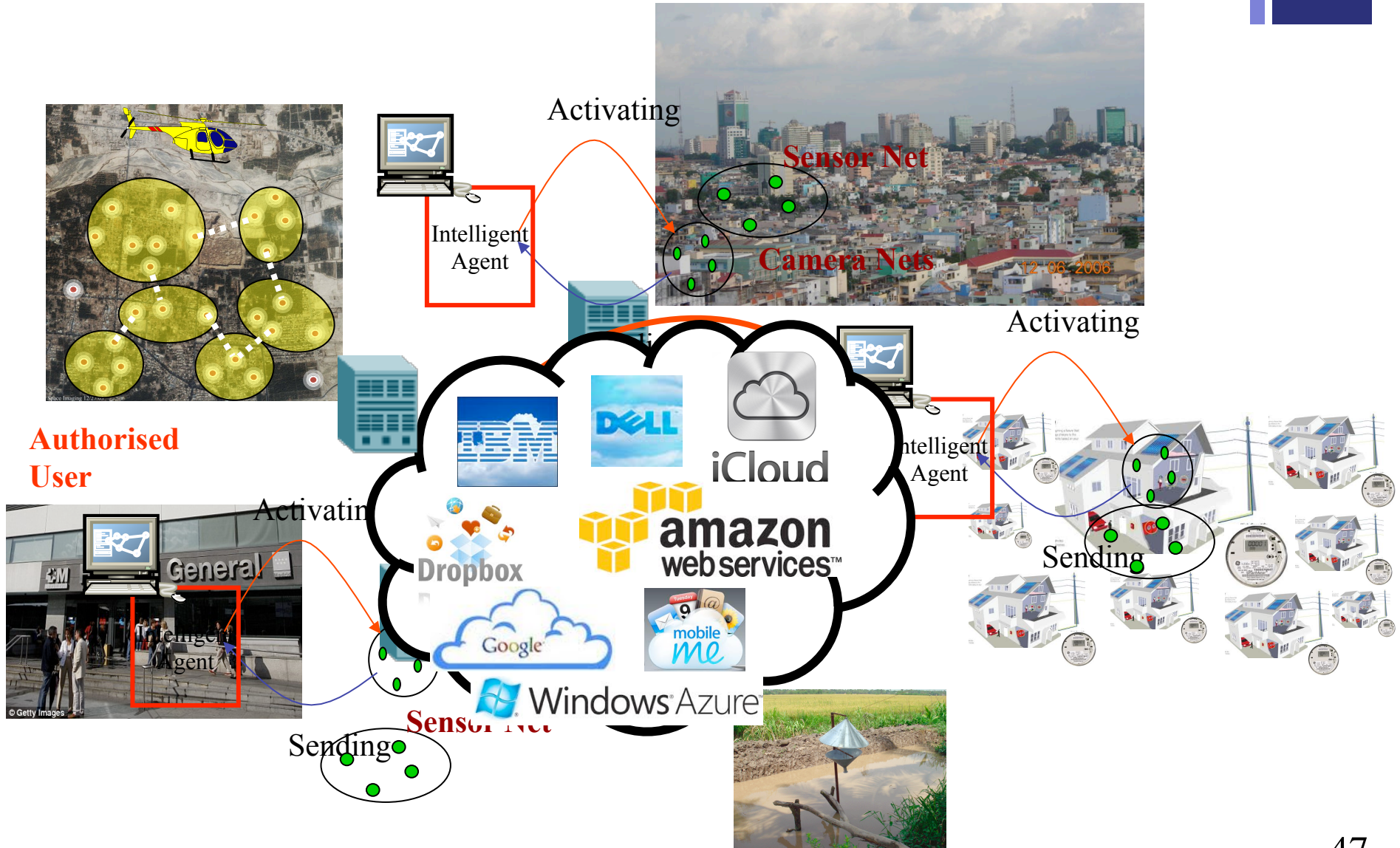
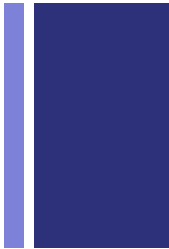

+ QoS ON CLOUDS: GENERAL PICTURE

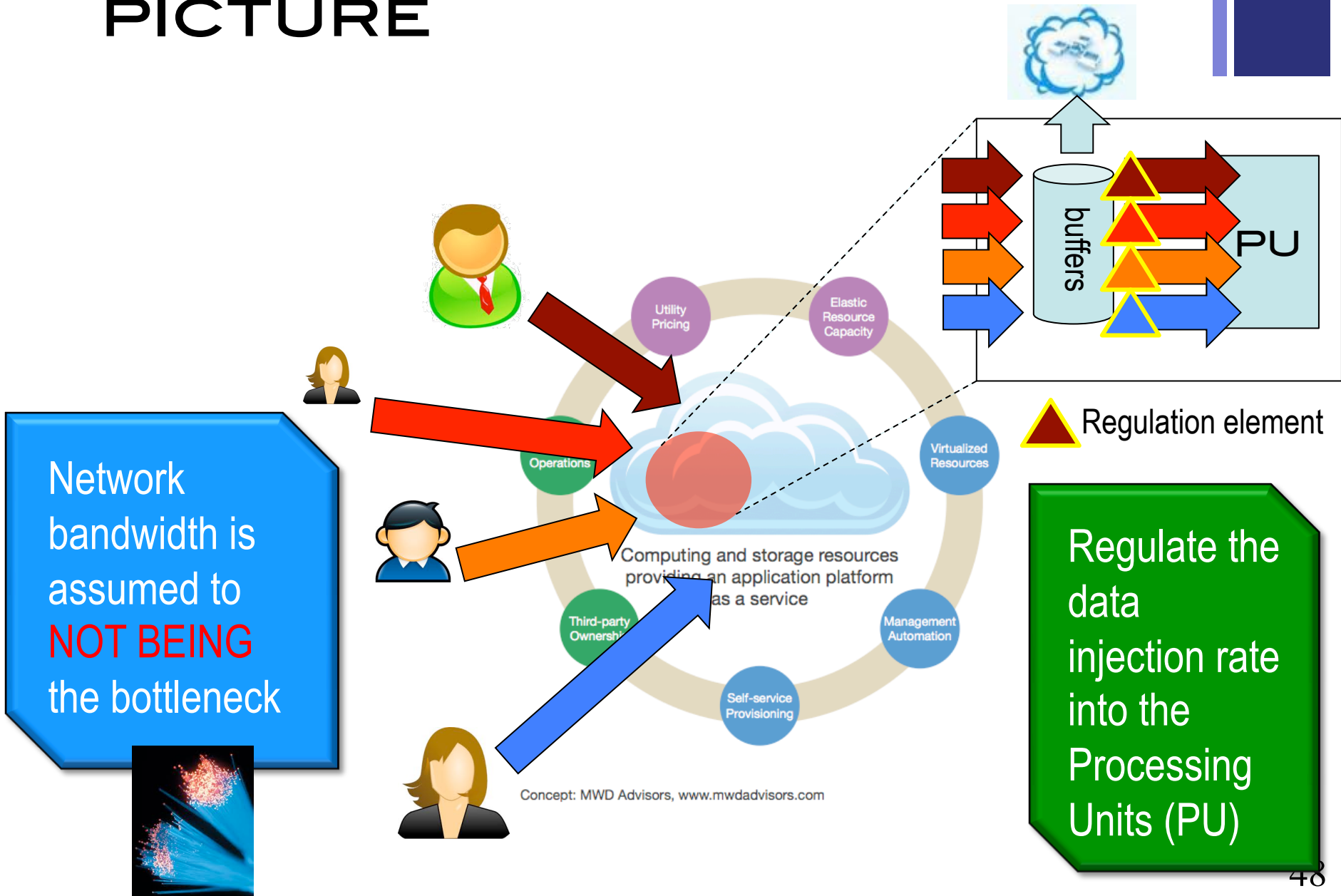



REGULATION PROCESS



NO NETWORKING QOS

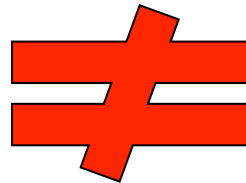

DON'T USE NETWORKING
QOS IDEAS

Rate regulation mechanisms are at the core of networking QoS architectures: IntServ, DiffServ, ...
QoS requires traffic characterization!

+ TRAFFIC AND SERVICE CHARACTERIZATION



□ DEFINITIONS

- CLOUD INFRASTRUCTURE (CI)
- PROCESSING UNITS (PU)

□ TO QUANTIFY A SERVICE ONE HAS TWO KNOW

- FLOW'S TRAFFIC ARRIVAL
- SERVICE PROVIDED BY THE CI, I.E., RESOURCES RESERVED AT PU

□ IDEAS ARE TO

- BOUND THE DATA INJECTION RATE TO...
- ...ISOLATE USERS FROM EACH OTHERS AND...
- ...TO PROVIDE QOS ENFORCEMENT AT FLOW LEVEL.



IDEAS BEHIND REGULATION



- USER DECLARES TRAFFIC PROFILE (EG, DATA INJECTION RATE); TRAFFIC IS METERED AND SHAPED IF NON-CONFORMING

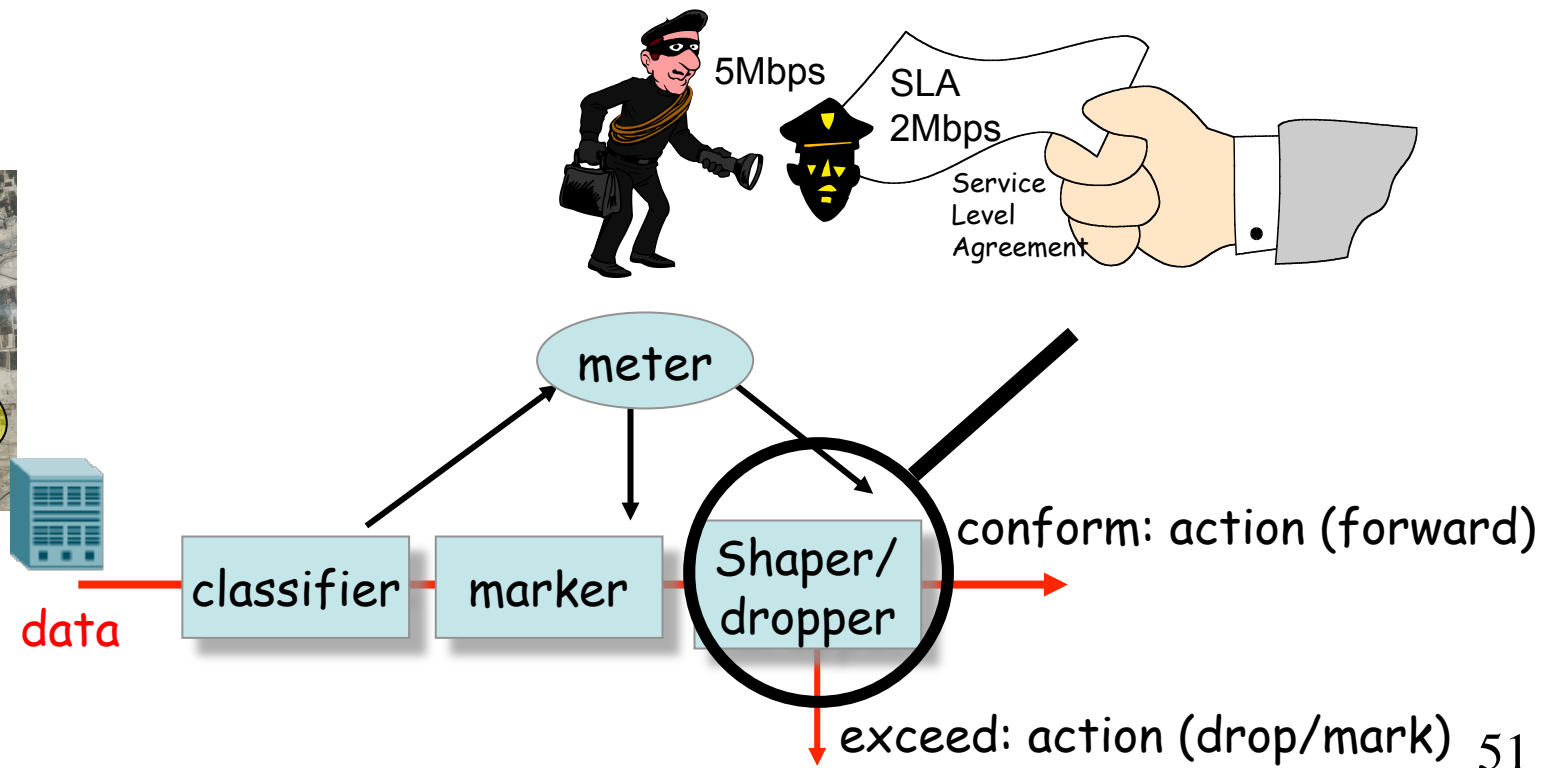
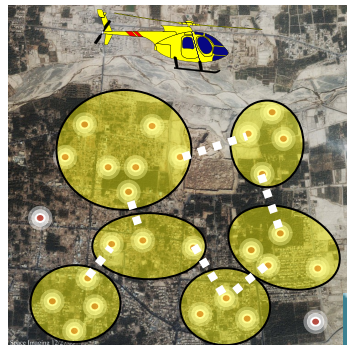



HOW TO REGULATE?



□ POLICING VS SHAPING

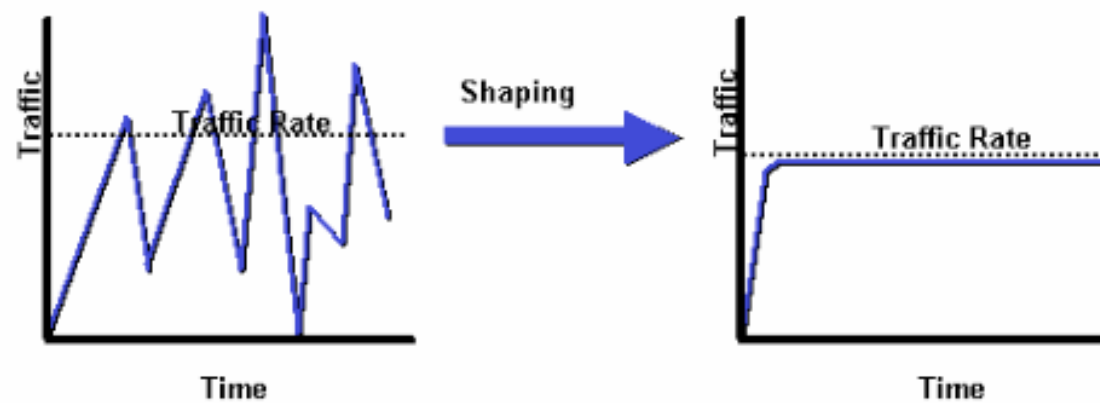
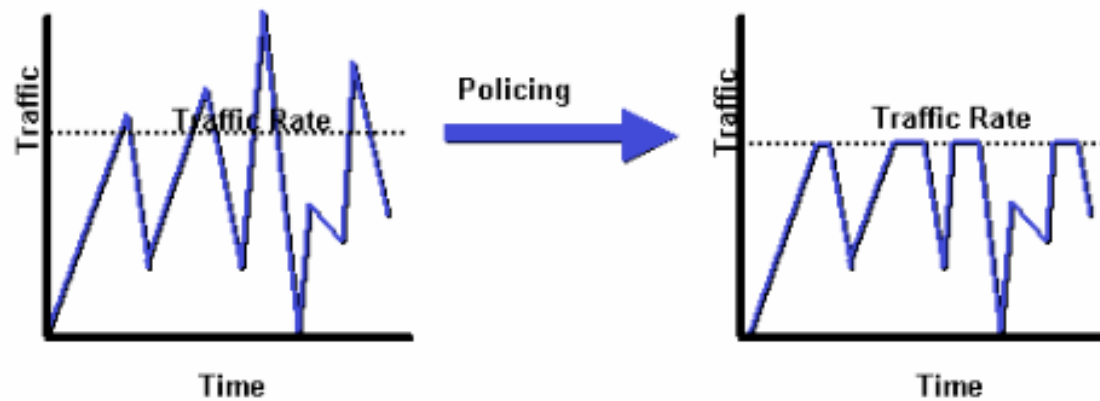



HOW TO SHAPE?



□ CONSTANT VS DYNAMIC

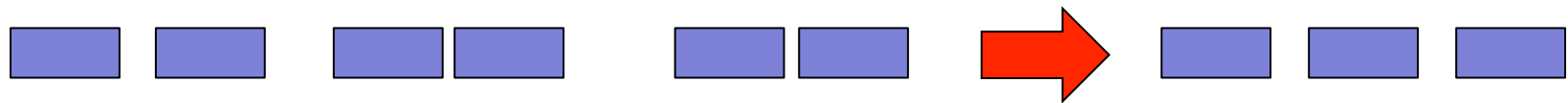

□ DYNAMIC

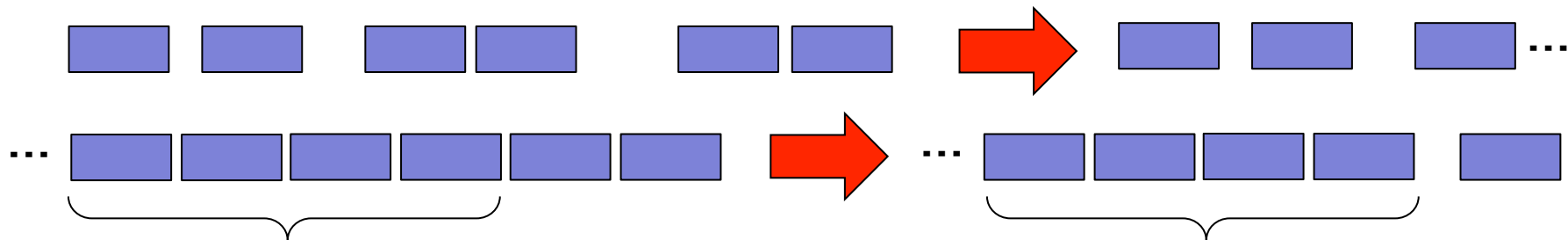

Dynamic shaping allows for variable data injection rate (variable sensing rate for instance). Need however to bound the amount of provided service per time period T .

+ TRAFFIC ENVELOPE (ARRIVAL CURVE)



- MAXIMUM AMOUNT OF SERVICE THAT A FLOW CAN REQUEST DURING AN INTERVAL OF TIME T

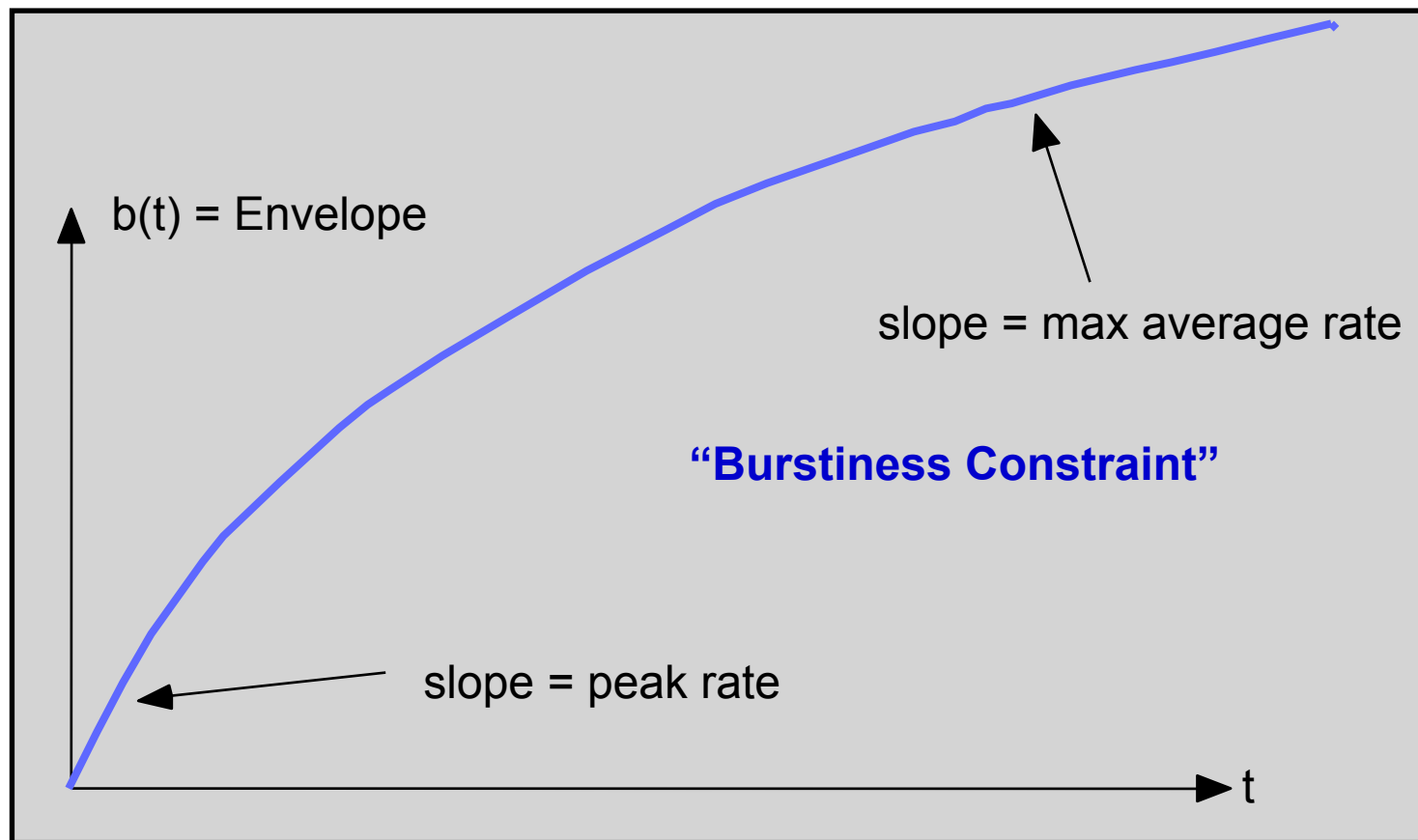

+ TRAFFIC ENVELOPE (TRAFFIC SHAPING)

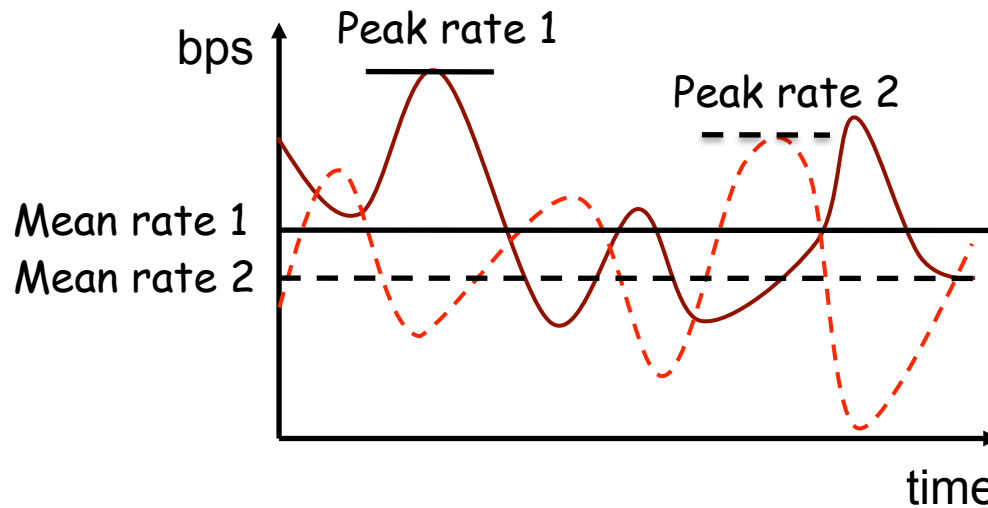

Traffic are variable by nature, must take into account burstiness constraints

Use an envelope process to bound the data injection rate while allowing for variable, bursty traffic

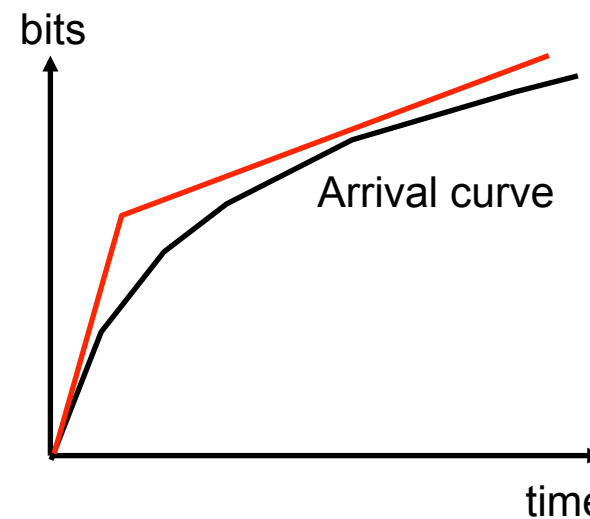
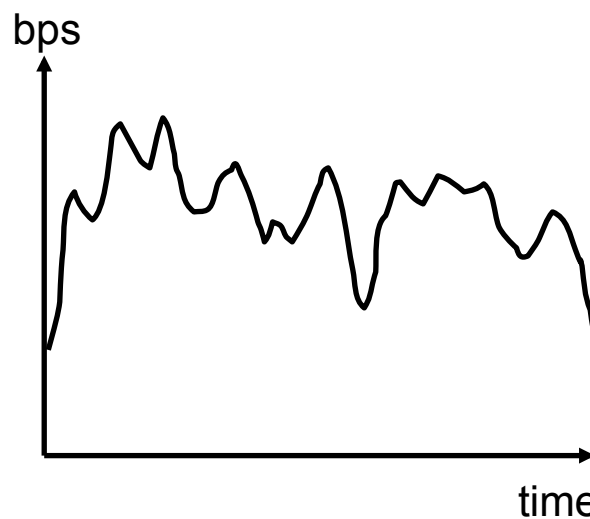



TOKEN BUCKET MODEL



- ❑ CHARACTERIZED BY THREE PARAMETERS (B, R, C)
 - ❑ B – TOKEN DEPTH
 - ❑ R – AVERAGE ARRIVAL RATE
 - ❑ C – MAXIMUM DATA INJECTION RATE
- ❑ A BIT IS TRANSMITTED ONLY WHEN THERE IS AN AVAILABLE TOKEN
 - ❑ WHEN A BIT IS TRANSMITTED EXACTLY ONE TOKEN IS CONSUMED

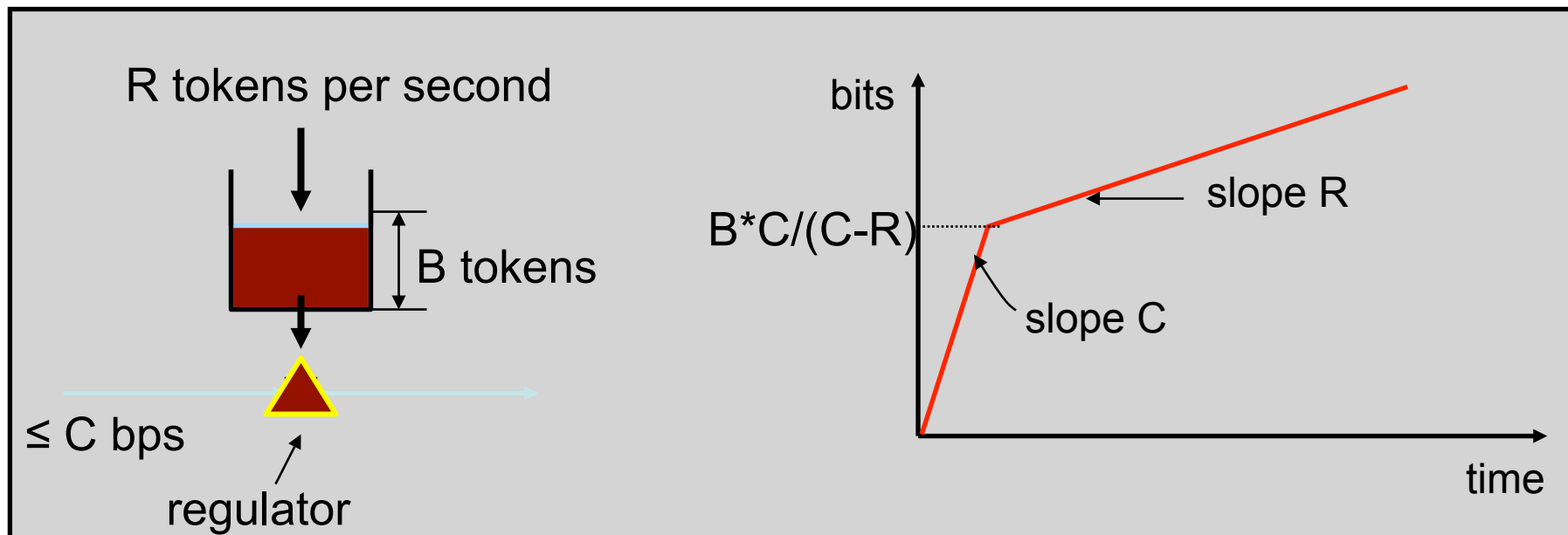



TOKEN BUCKET EXAMPLE (1)



Example

- $B = 4000$ bits, $R = 1$ Mbps, $C = 10$ Mbps
- Packet length = 1000 bits
- Assume the bucket is initially full and a “large” burst of packets arrives

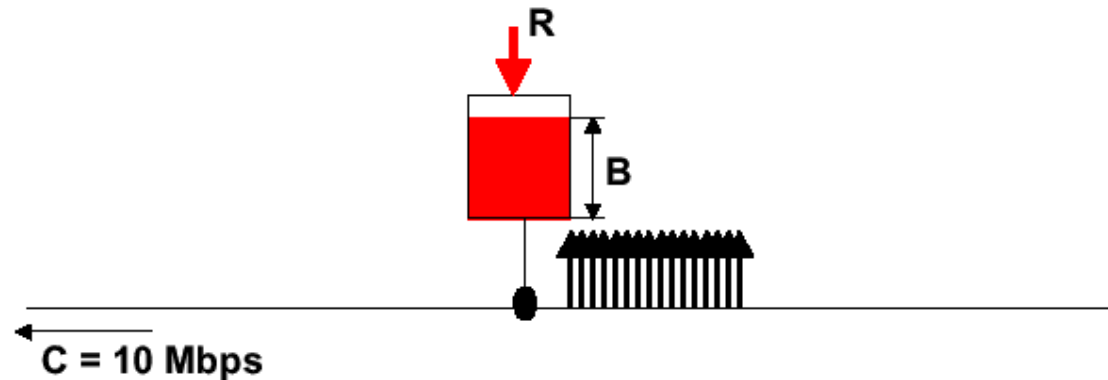

istoica@cs.cmu.edu



TOKEN BUCKET EXAMPLE (2)

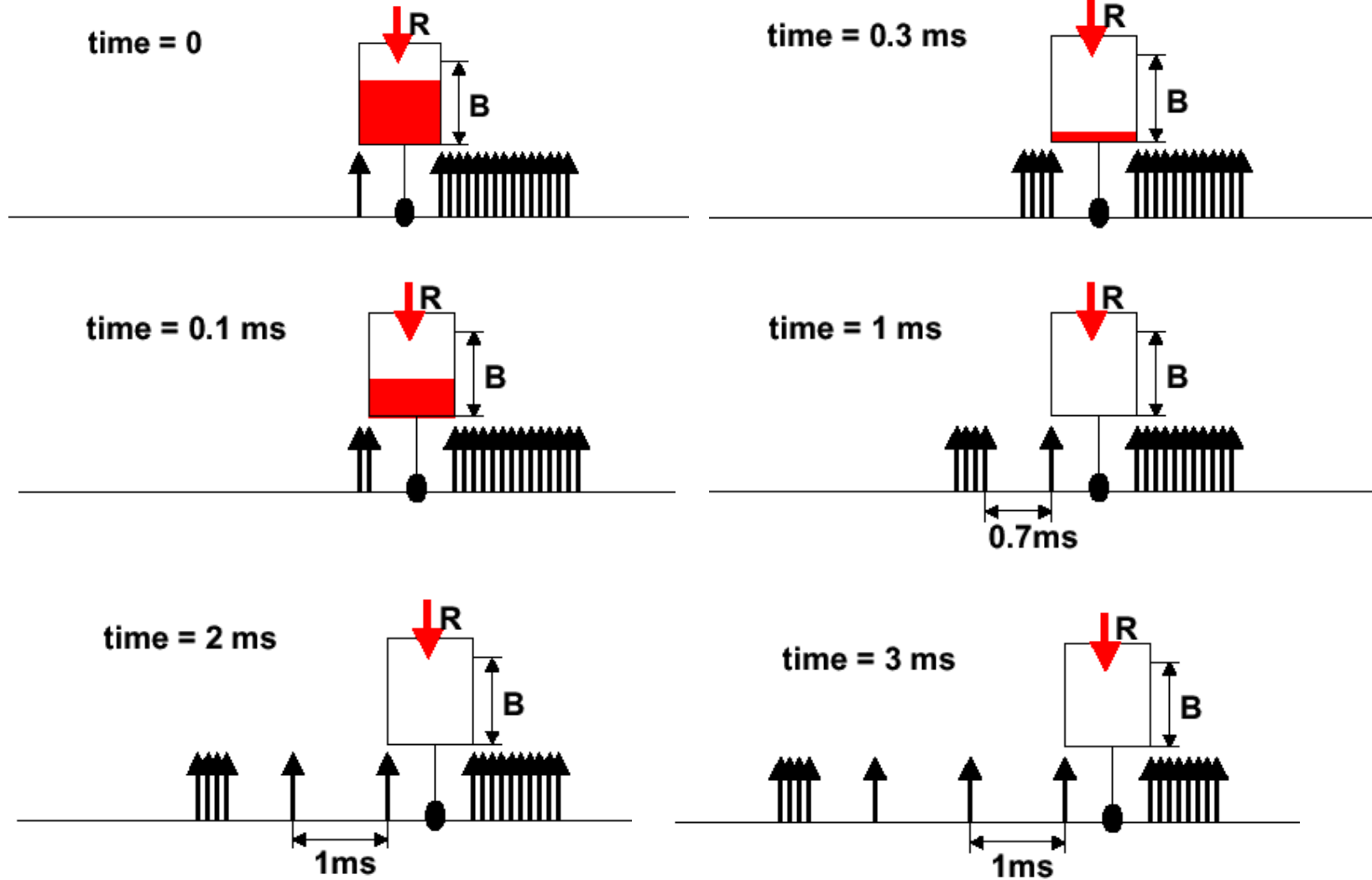



ARRIVAL CURVE



$A(t)$ – number of bits received up to time t

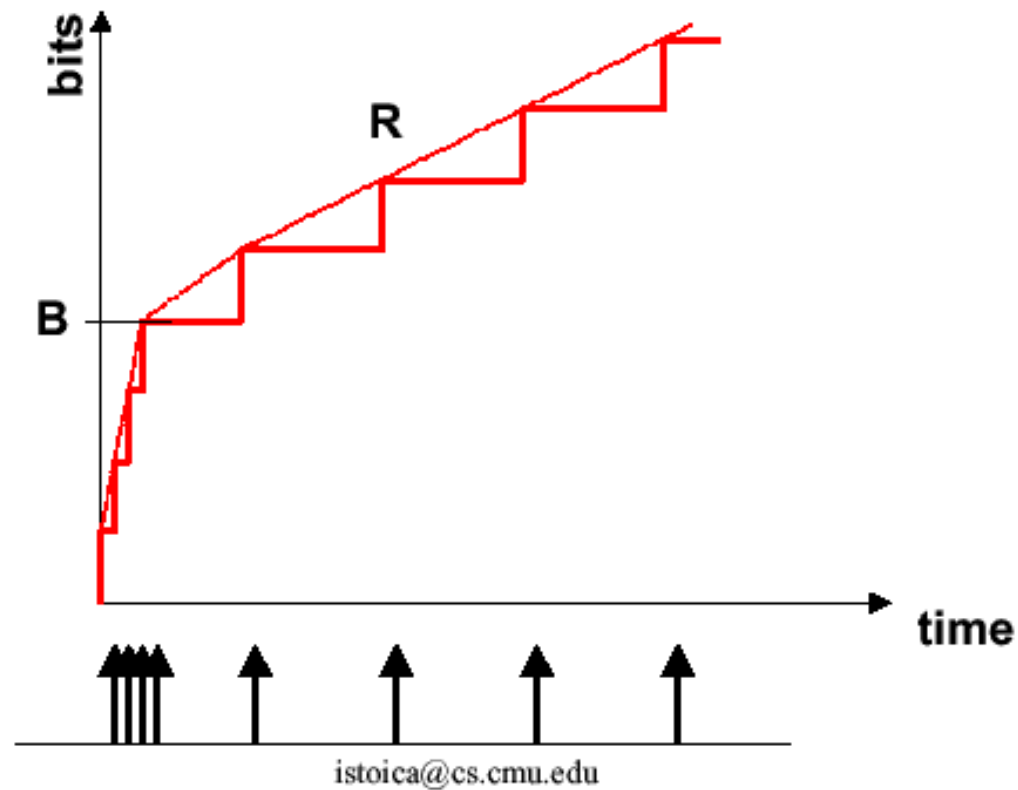

+ PER-HOP RESERVATION WITH TOKEN BUCKET

- ❑ GIVEN B, R, C AND PER-HOP DELAY D
- ❑ ALLOCATE RESOURCE R_A AND BUFFER SPACE B_A SUCH THAT TO GUARANTEE D

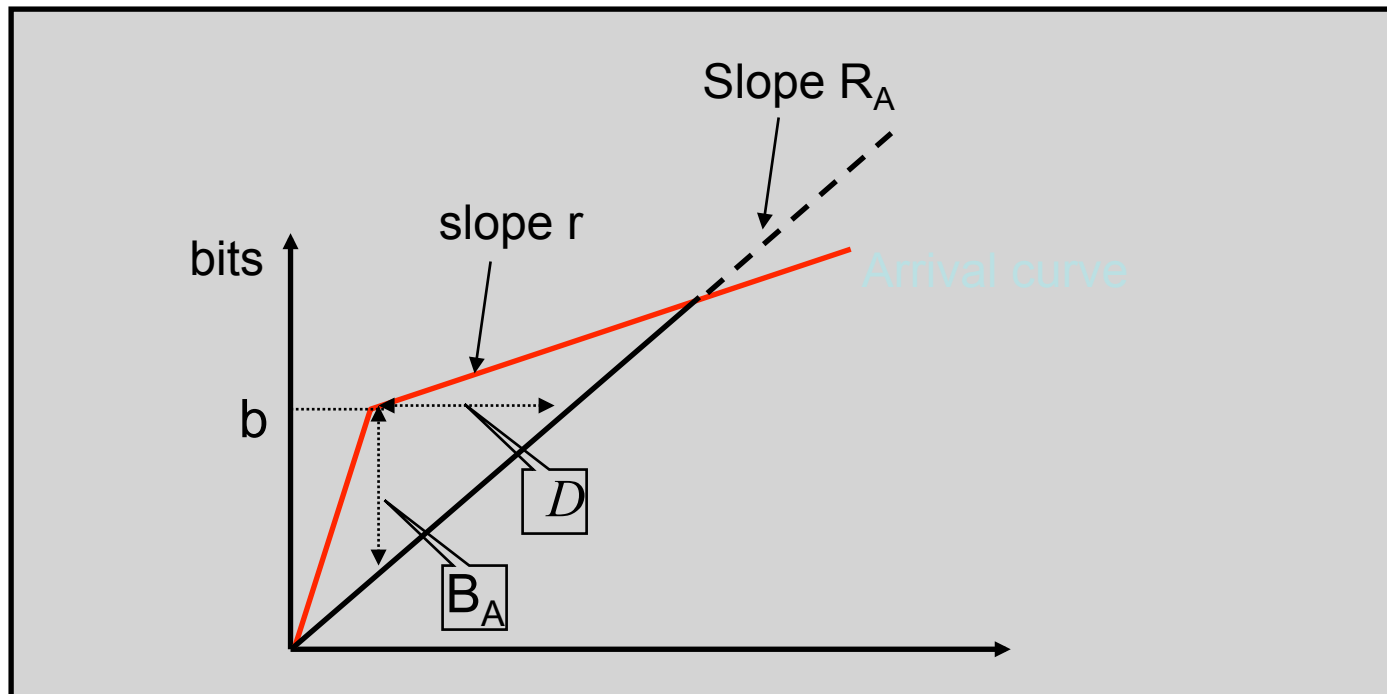



SERVICE MODEL

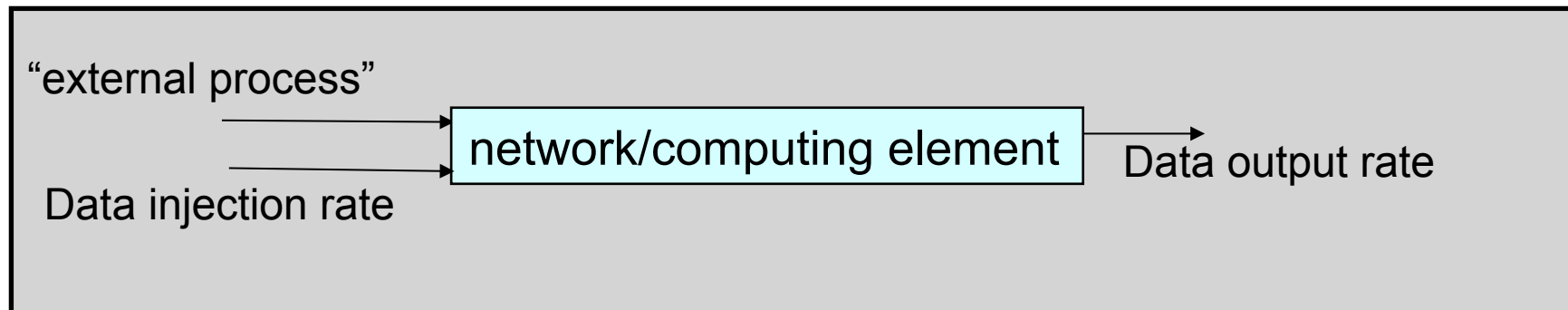

- ❑ THE QOS MEASURES (DELAY, THROUGHPUT, LOSS, COST, ...) DEPEND ON OFFERED TRAFFIC, AND POSSIBLY OTHER EXTERNAL PROCESSES.
- ❑ A SERVICE MODEL ATTEMPTS TO CHARACTERIZE THE RELATIONSHIP BETWEEN INPUTS, OUTPUTS, AND POSSIBLY OTHER EXTERNAL PROCESSES.

+ ARRIVAL AND DEPARTURE PROCESS

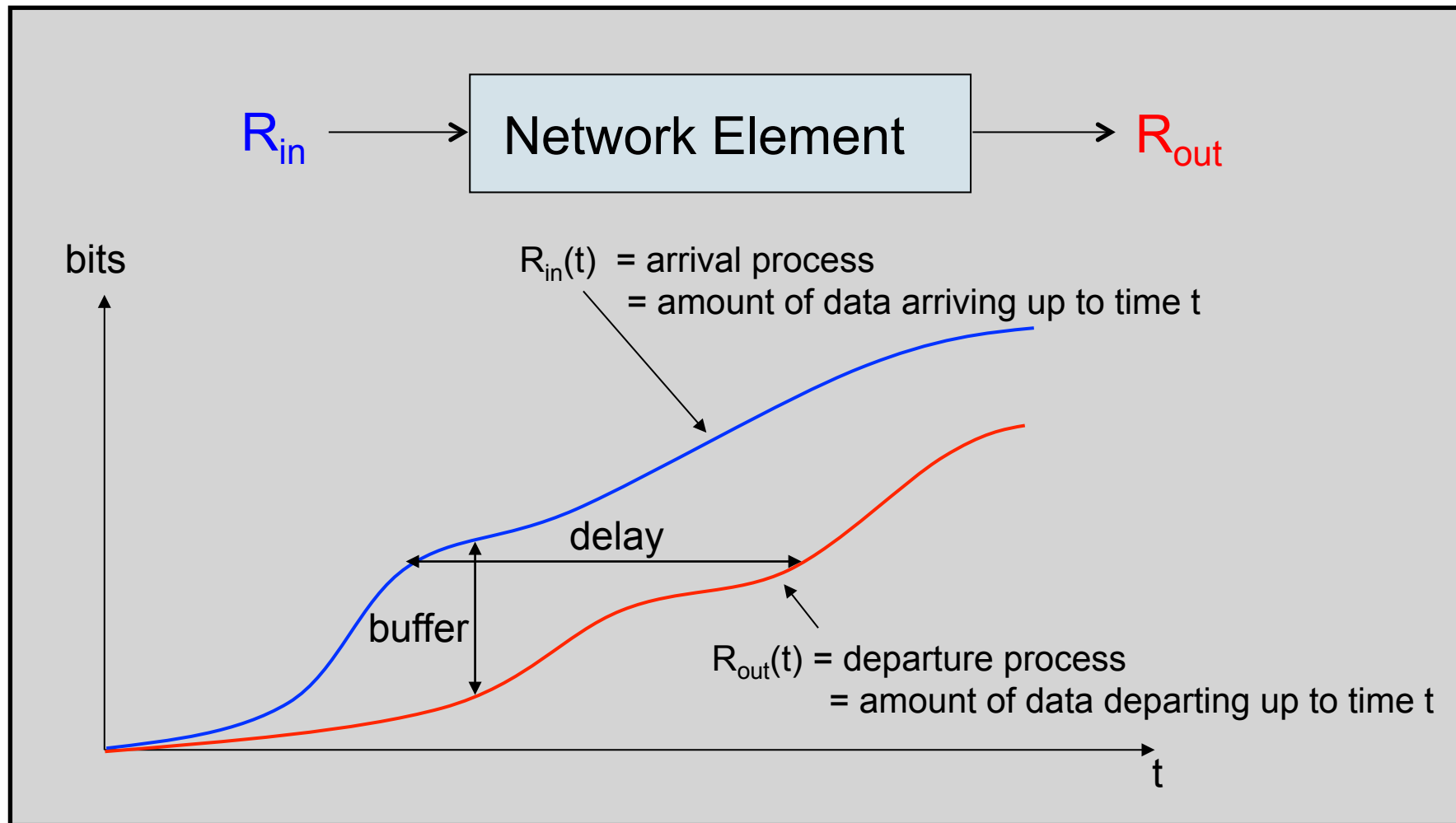

+ DELAY AND BUFFER BOUNDS

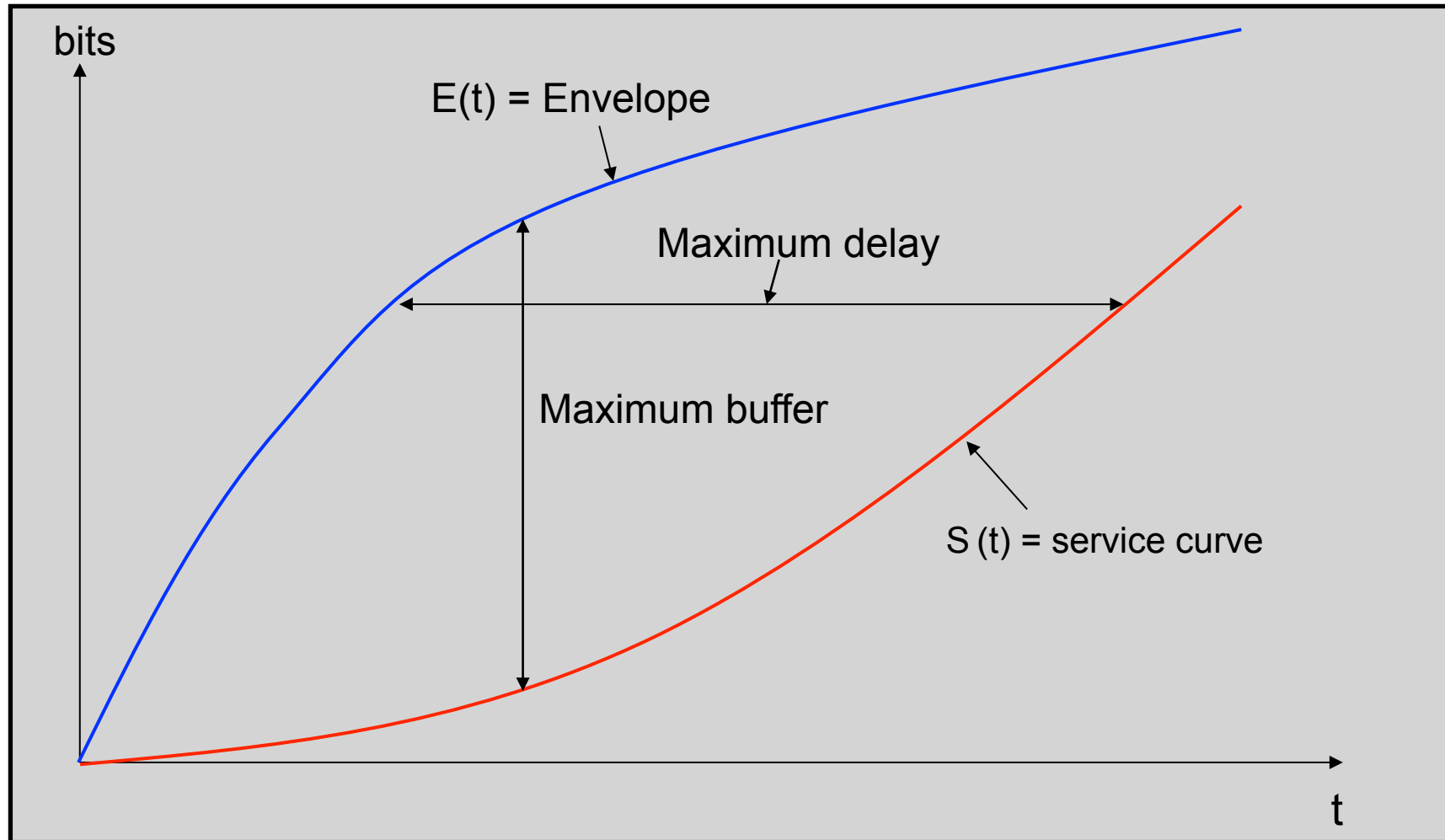



WHERE TO PUT QOS?

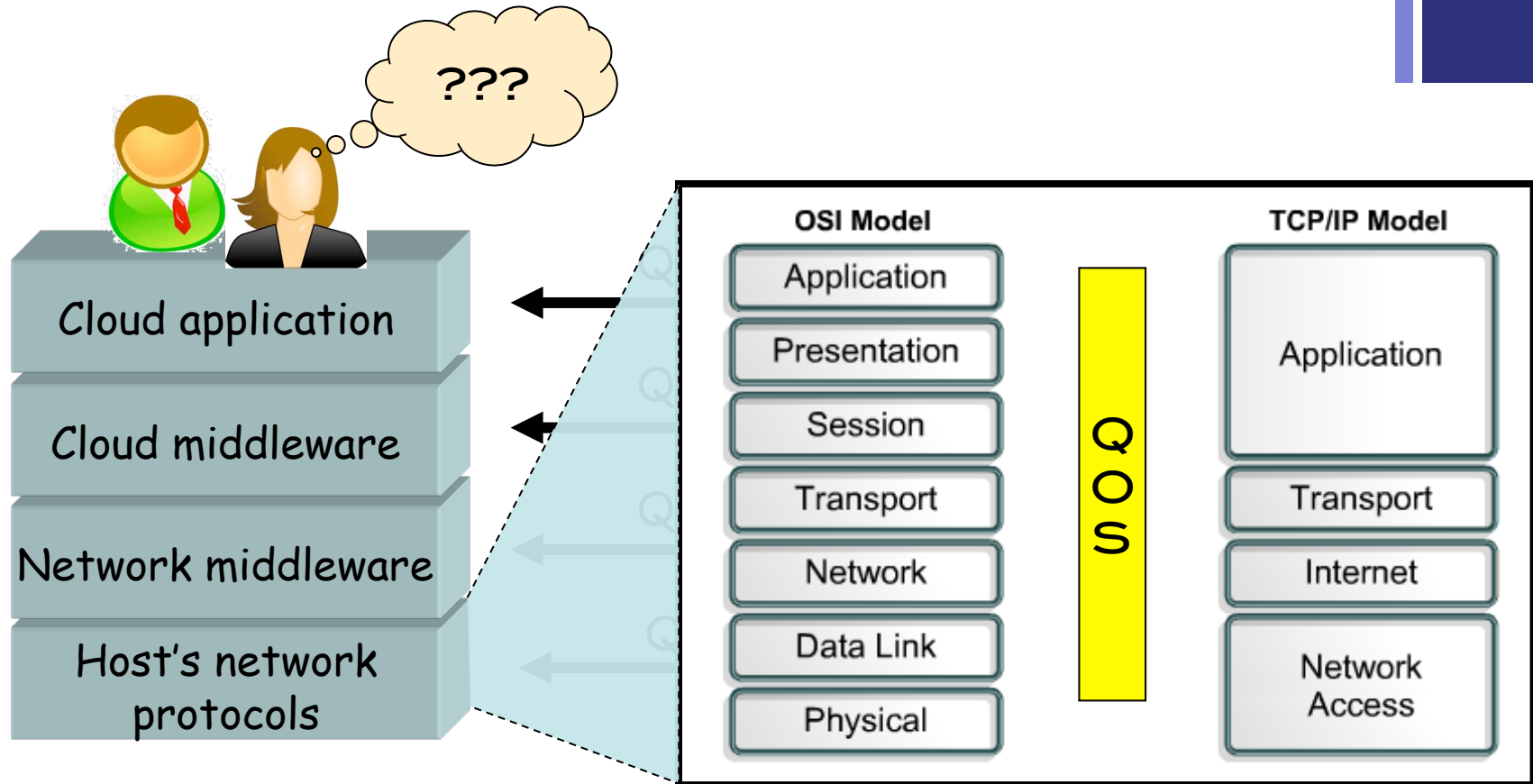

Need to better understand the purpose of data processing from various user communities: scientific, business, industrial,



SCIENTIFIC EXPERIMENT



- CONSISTS OF COLLECTIONS OF DATA THROUGH OBSERVATION AND EXPERIMENTATION, AND THE FORMULATION AND TESTING OF HYPOTHESES.

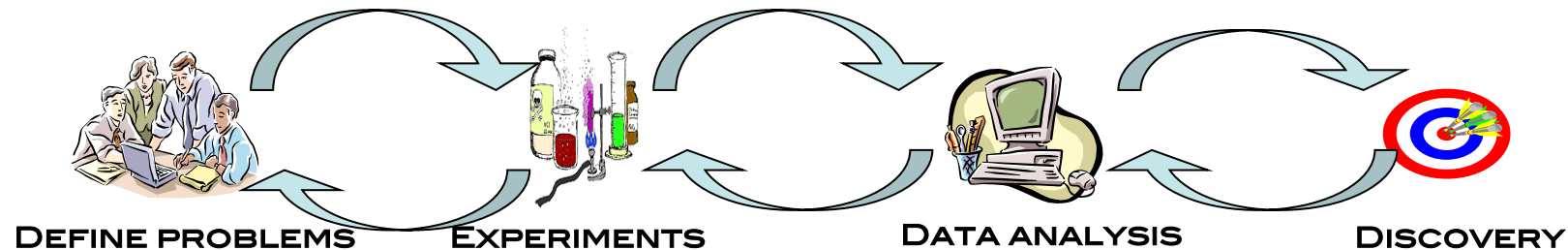

ACTIVITIES ARE ITERATIVE, DYNAMIC, AND HUMAN STEERED !!

BUSINESS PROCESSES

- The workflow concept has existed for decades
 - *Representation, Specification, and Automation of **Office** Procedures*
- They are very popular to manage **business processes as document interchanges**
- Workflow Management System (WFMS) *is a system that defines, creates, and manages the execution of workflows*
 - *Support for **large scale programming** (different time scale)*
 - ***Fault tolerance** support*
 - ***Interact** with participants*
 - ***Invoke** Enterprise applications*
- *Component of EAI tools (Enterprise Application Integration)*

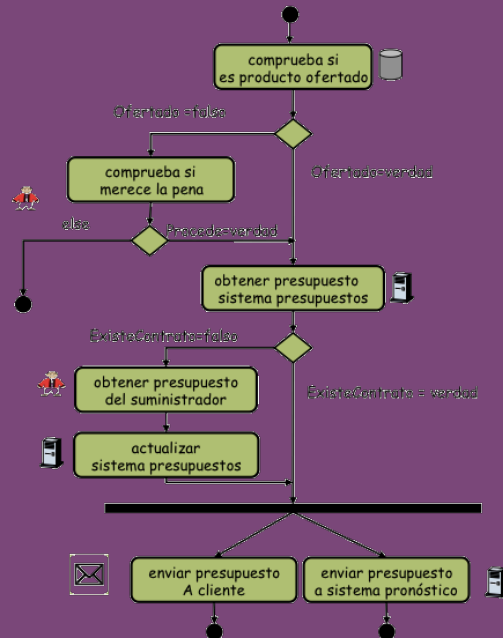

Workflow

“The automation of a business process, in whole or part, where documents, information or tasks are passed from one participant to another to be processed, according to a set of procedural rules “

Workflow Management Coalition (WfMC)

+ WORKFLOWS & SERVICE ORIENTED ARCHITECTURES

SLIDE TAKEN FROM J. BANARES, UNIV. ZARAGOZA

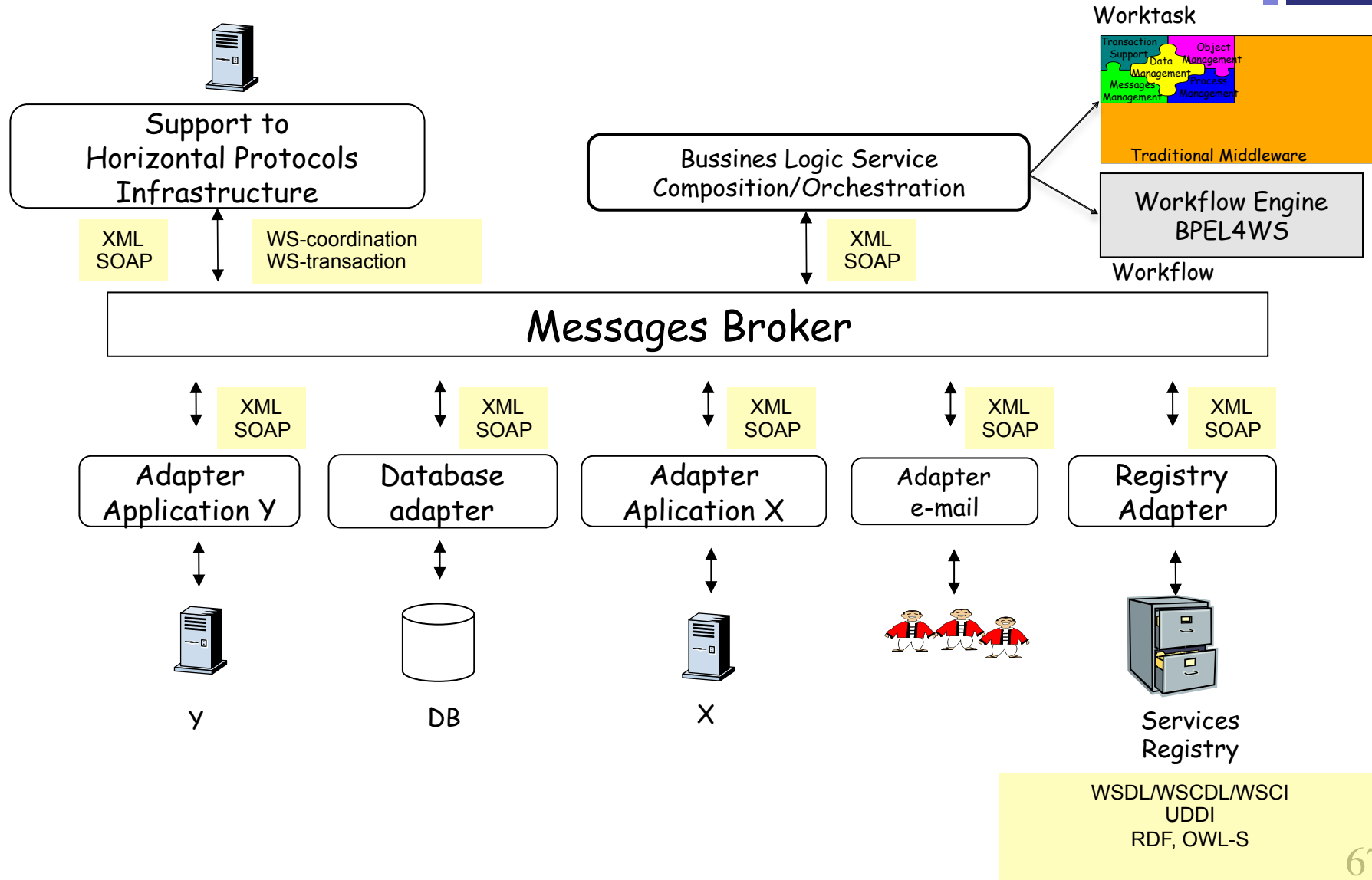

+ GENERAL PURPOSE WORKFLOWS



SLIDE TAKEN FROM J. BANARES, UNIV. ZARAGOZA

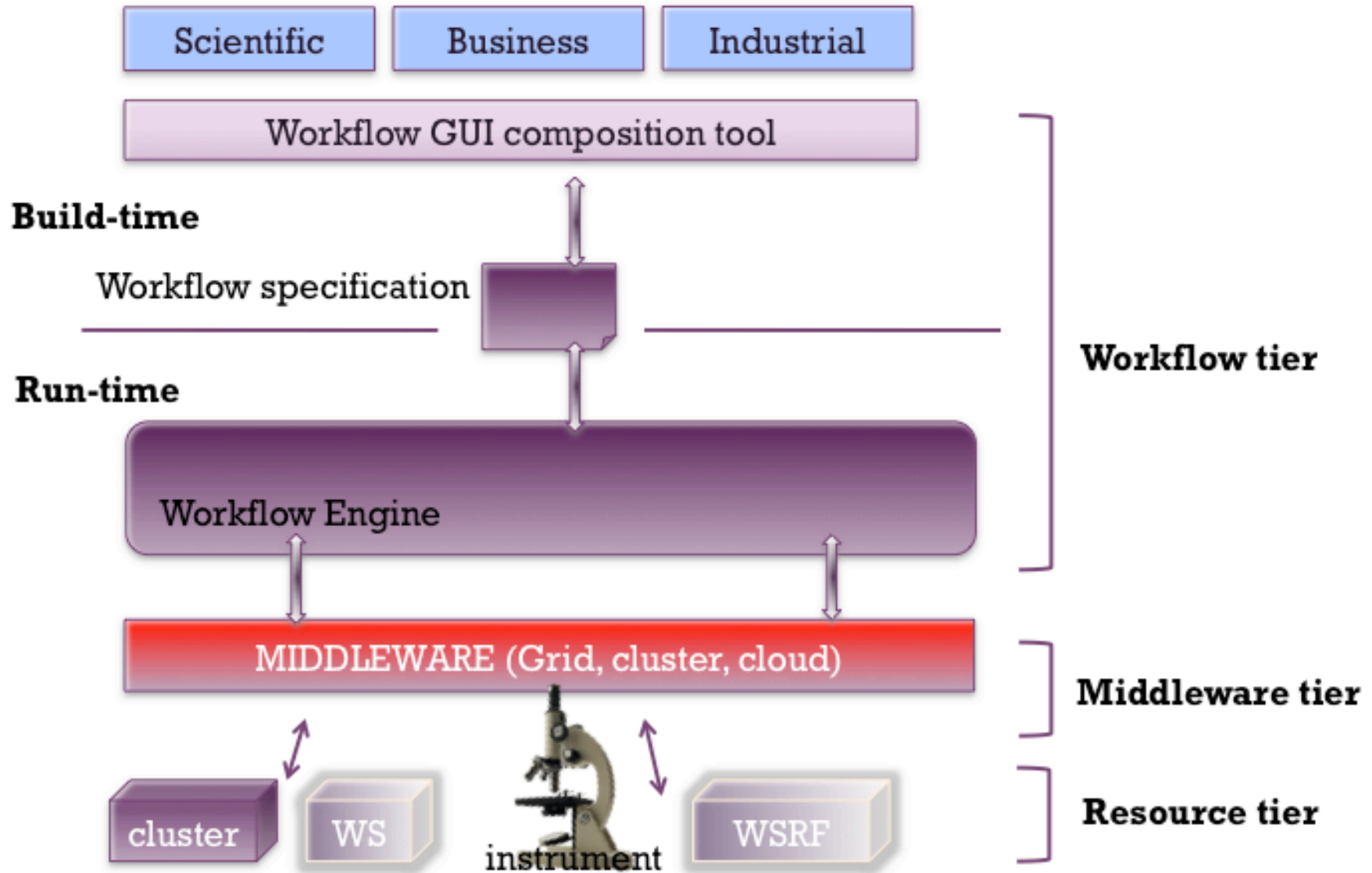



REFERENCE NETS (RN)

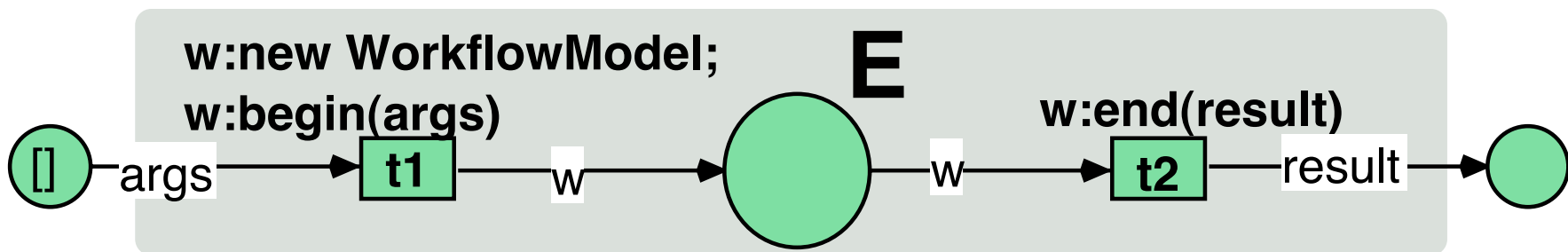
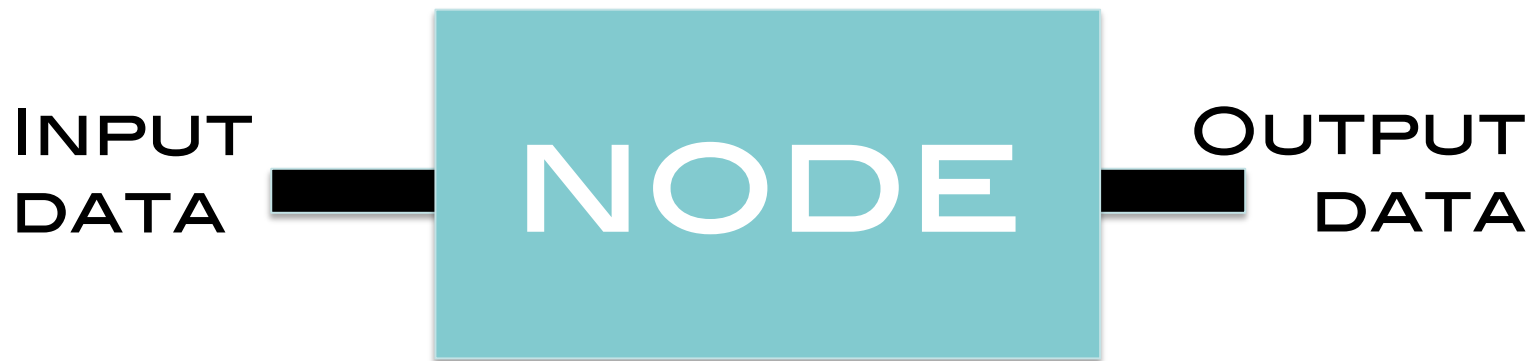
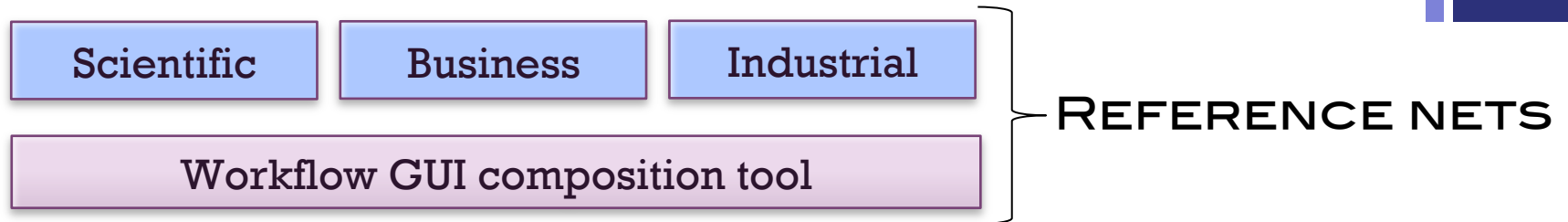



REFERENCE NETS & CLOUD

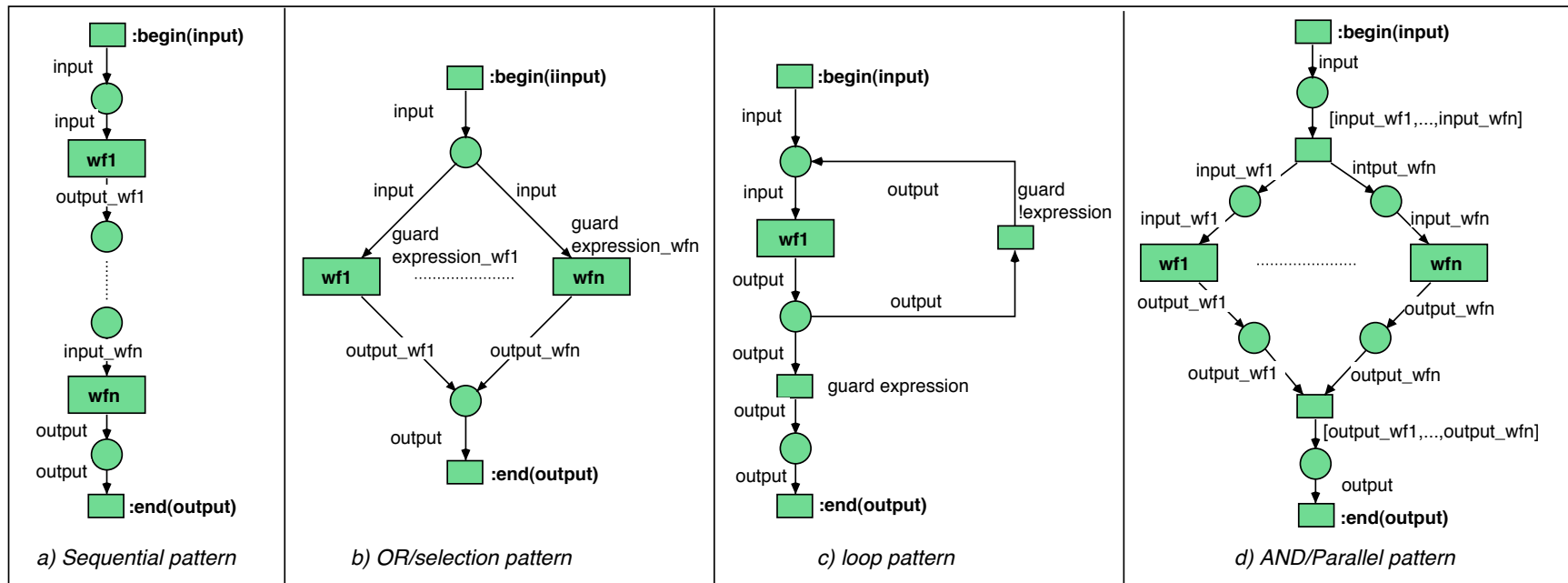
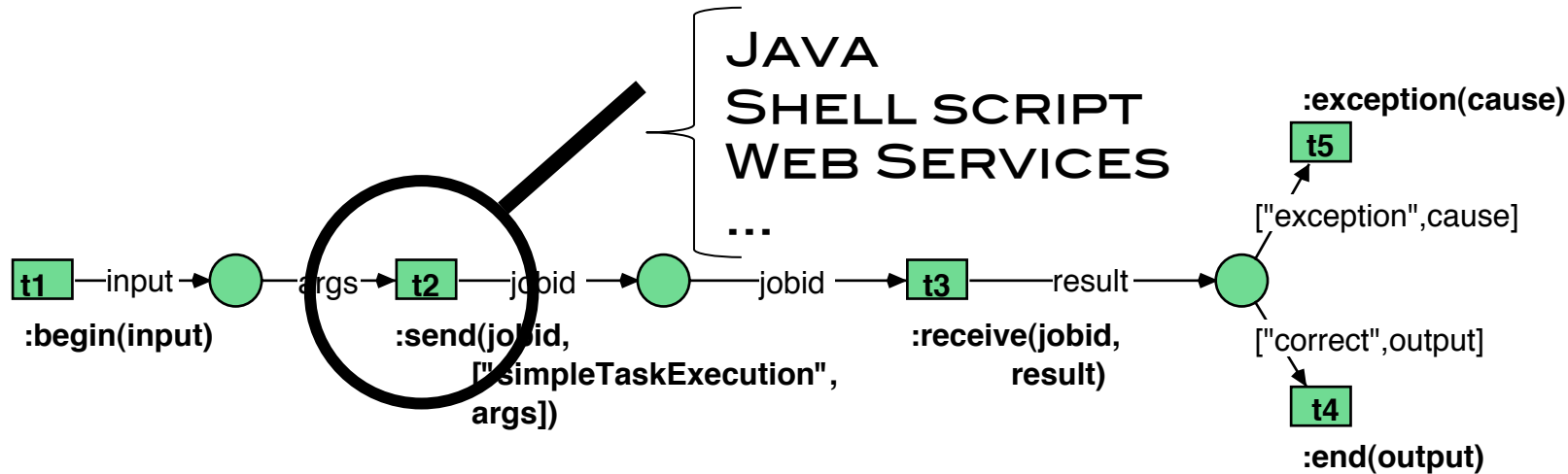

+ TOKEN BUCKET SUPPORT IN RNS WORKFLOWS

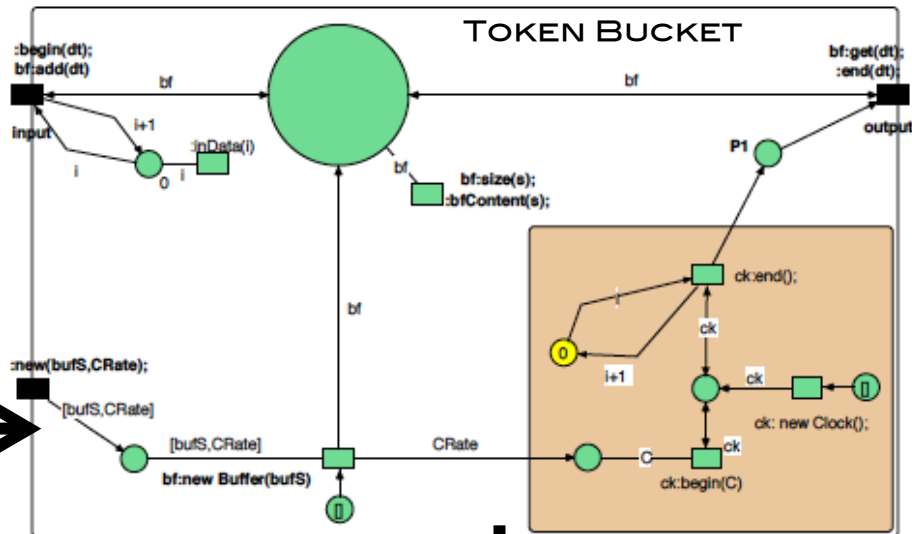
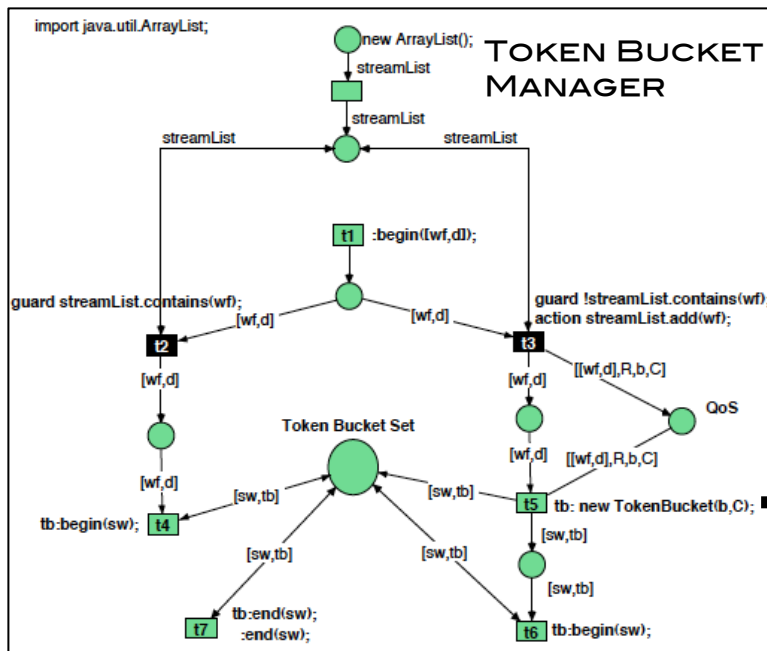

TB QoS is introduced seamlessly into workflow specifications with the Renew tools

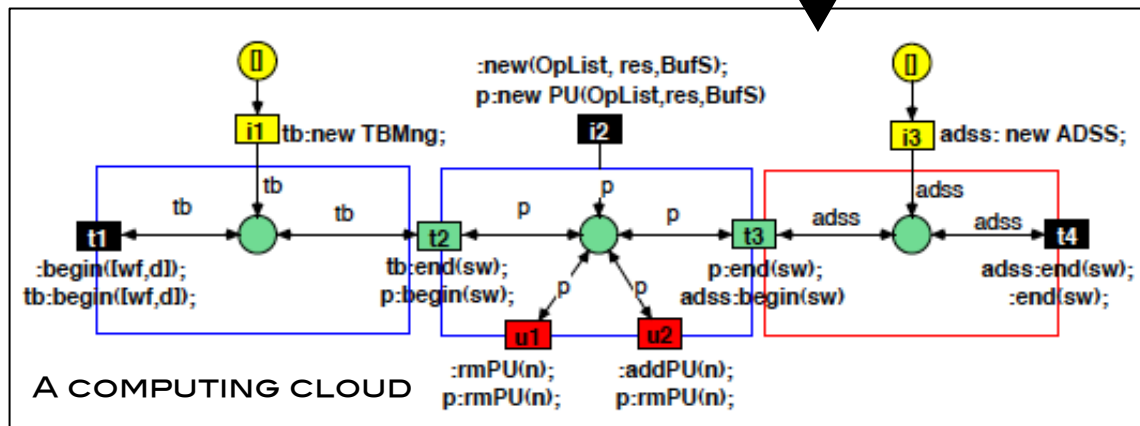



EVALUATION SCENARIO

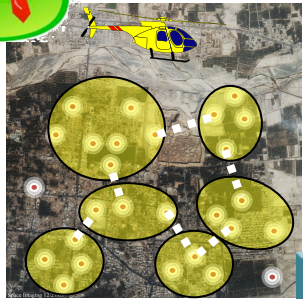

20 MB/s

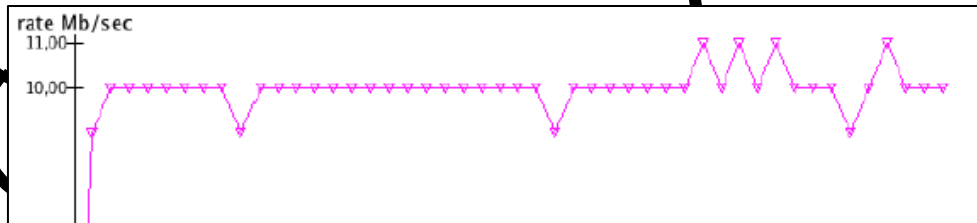
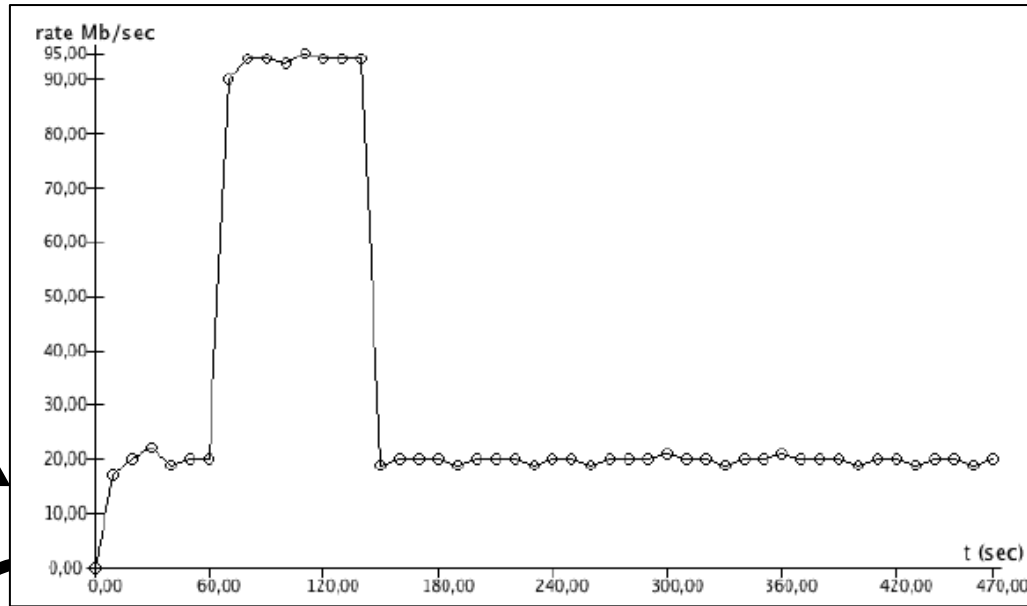

R. Tolosana, J. A. Banares, C. Pham, O. Rana. « Enforcing QoS in Scientific Workflow Systems Enacted Over Cloud Infrastructures ». To appear in Journal of Computer and System Science (JCSS), Elsevier. Special issue on Cloud Computing.

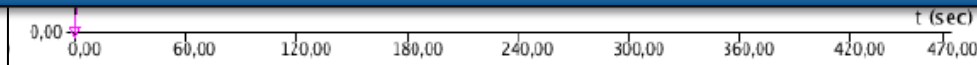



EVALUATION SCENARIO

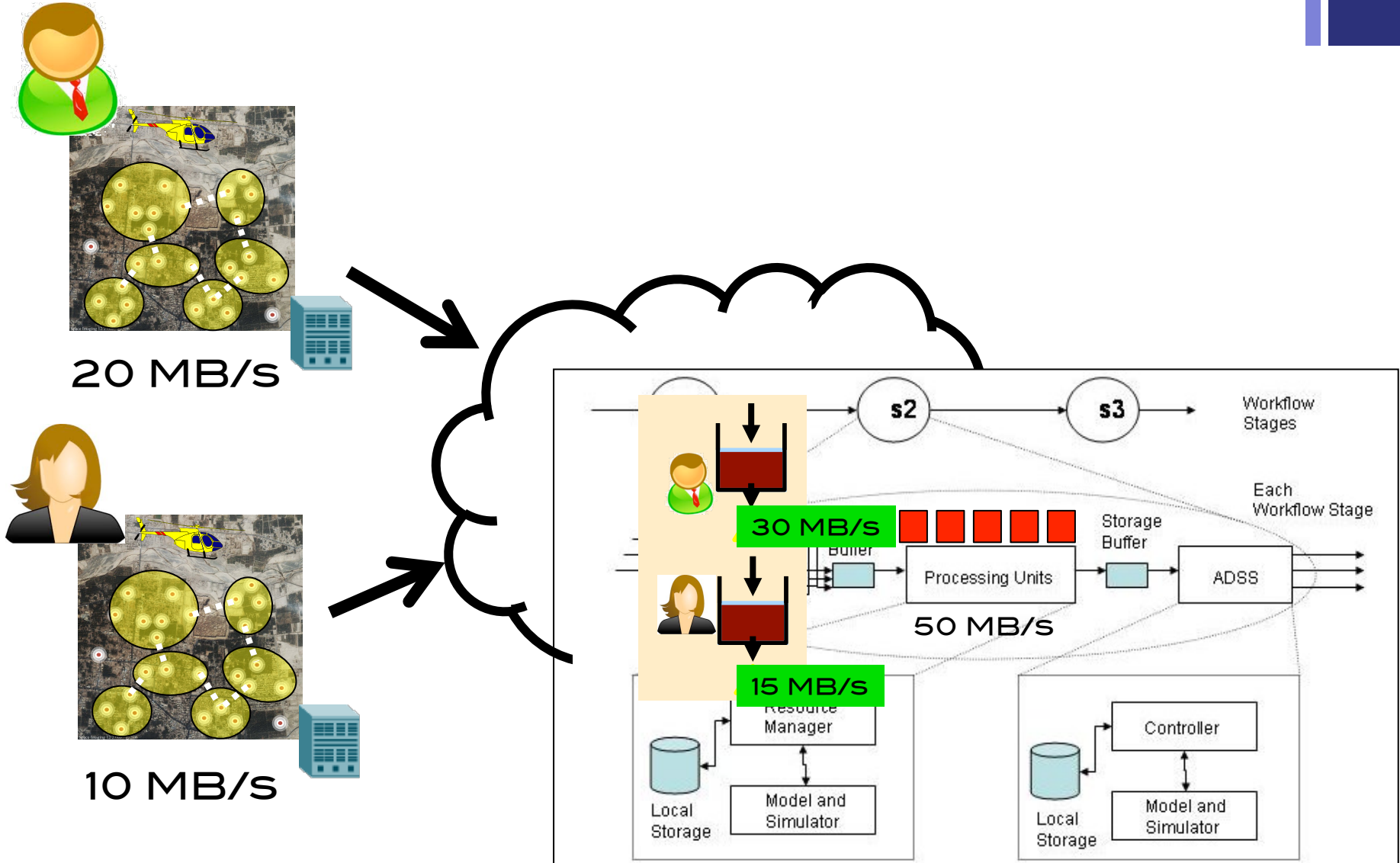



PERFORMANCE RESULTS

WITHOUT TOKEN BUCKET

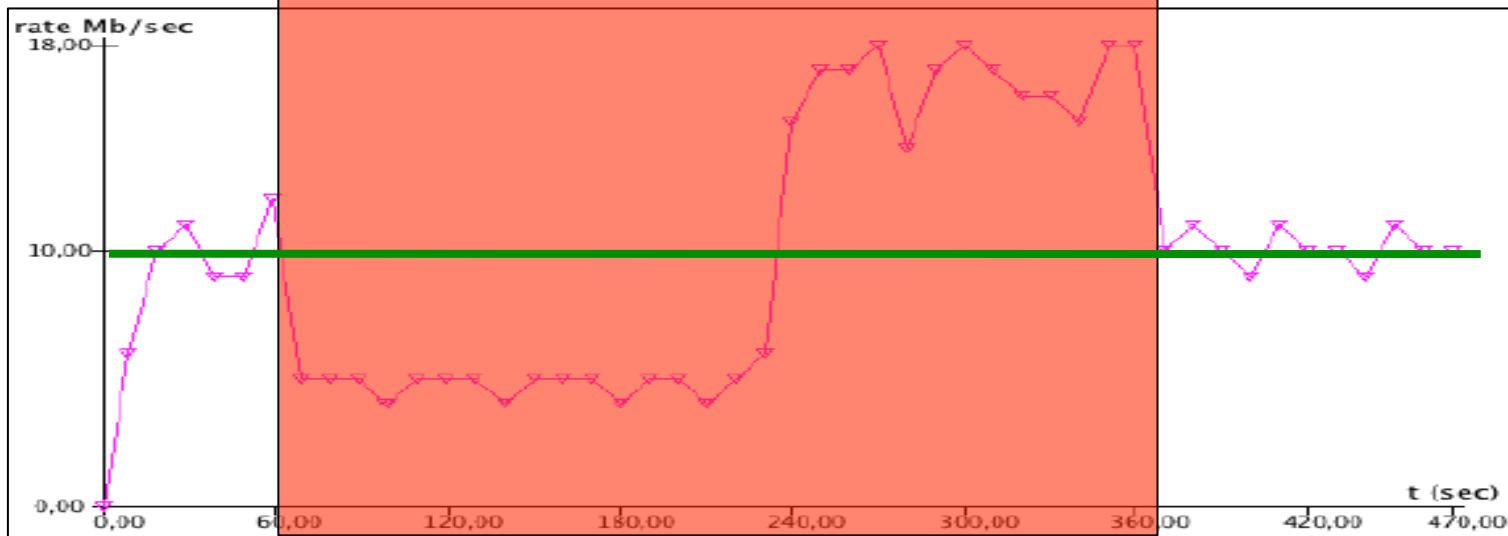
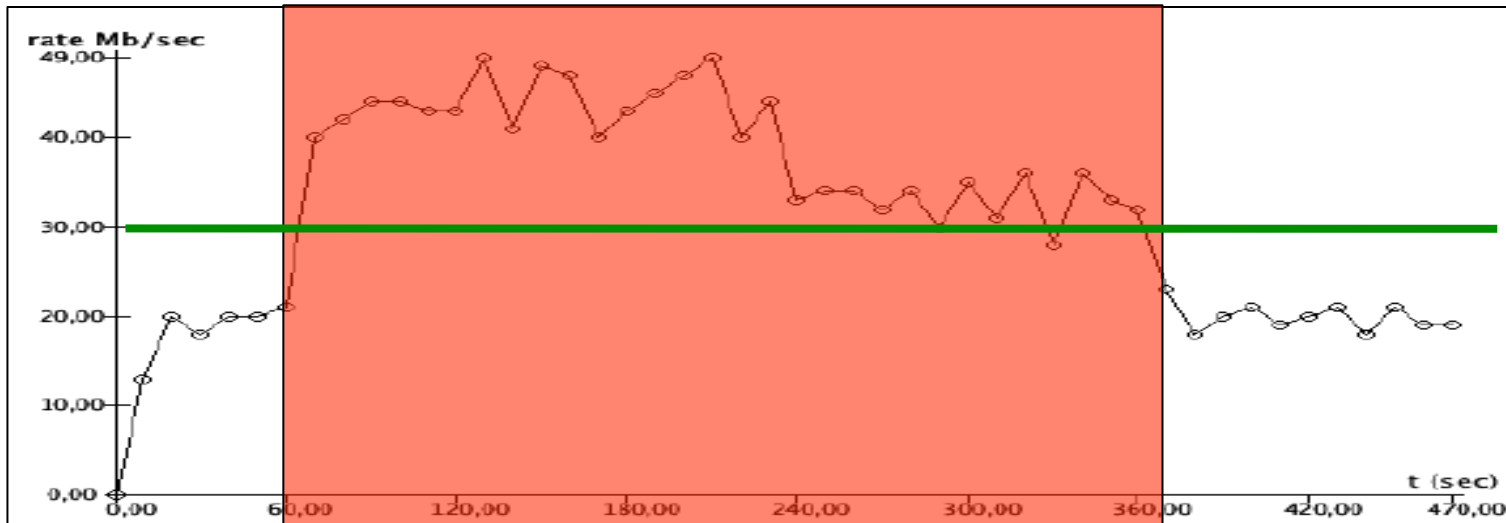
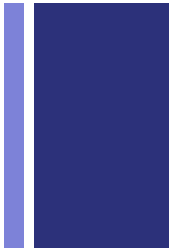



PERFORMANCE RESULTS

WITH TOKEN BUCKET

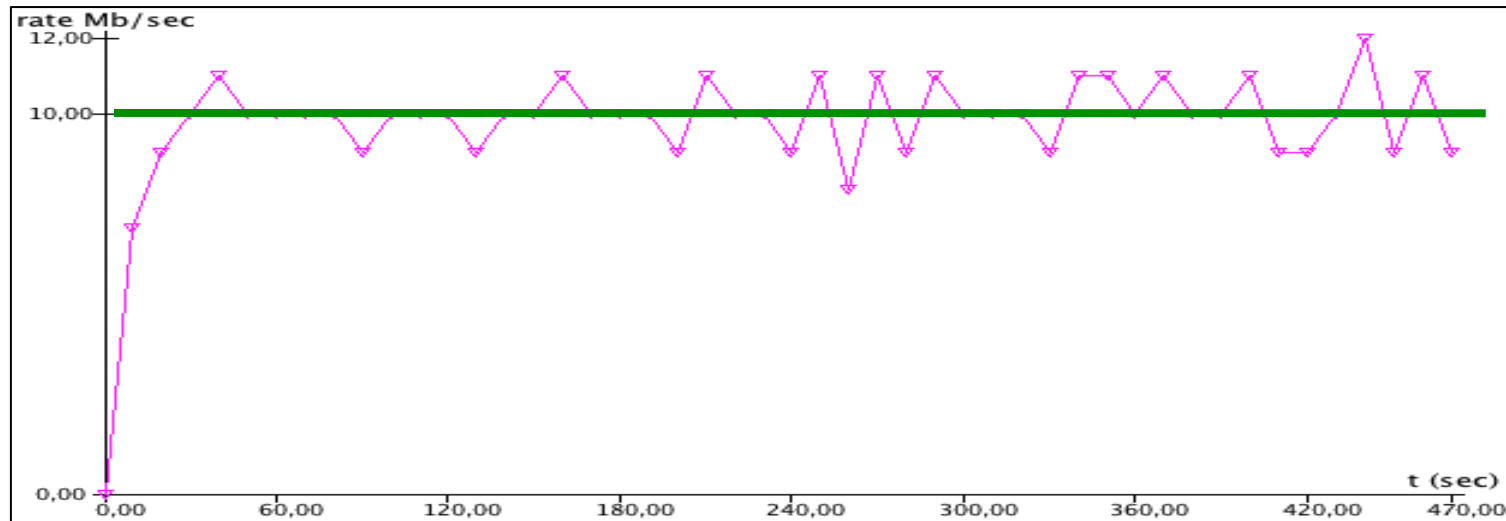
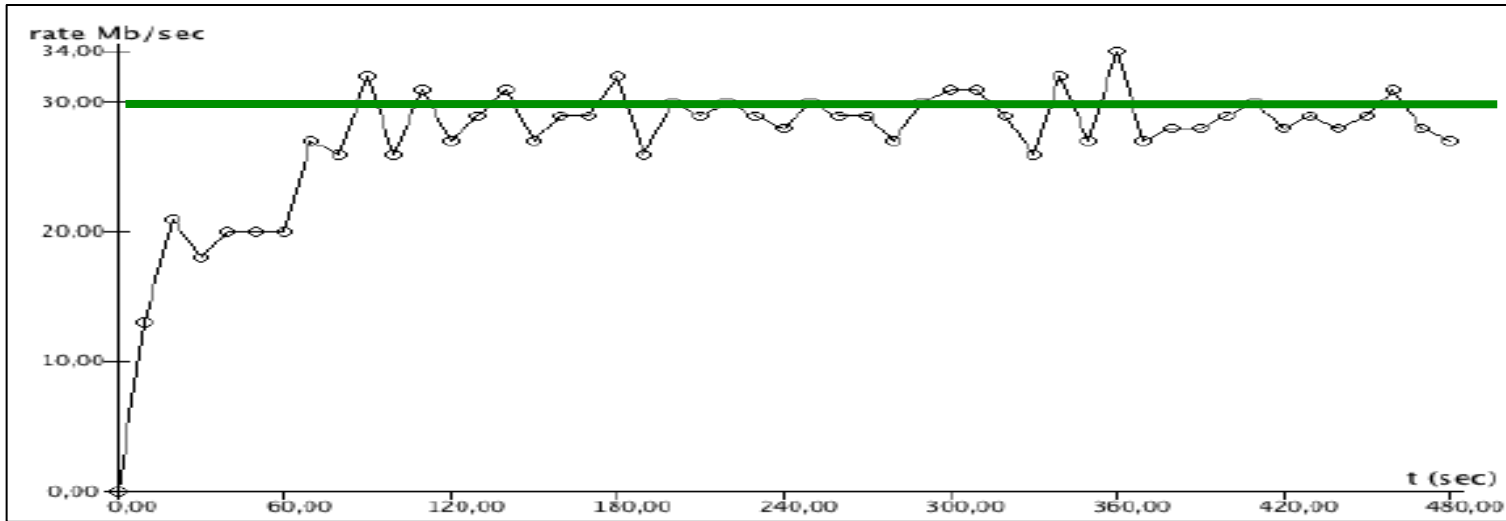
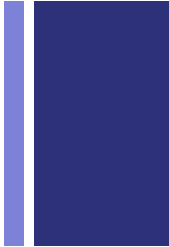



CONCLUSIONS (1)



- ❑ CLOUDS WILL BE SHARED CLOUDS DRIVEN BY ECONOMICAL CONSTRAINTS
- ❑ FOR SOME APPLICATIONS, AVAILABILITY OF RESOURCES AND ISOLATION ARE OF PRIME IMPORTANCE (URGENT COMPUTING)
- ❑ QOS FOR CLOUDS IS ALREADY A NECESSARY AND HOT TOPIC IN RESEARCH COMMUNITY



PERSPECTIVES (1)



- ❑ ADD MORE PARAMETERS TO THE TB MODEL
 - ❑ EXCESS BURST SIZE
 - ❑ MULTIPLE TOKEN BUCKET MODELS
 - ❑ ADVANCED MARK VS. DROP POLICY
- ❑ DYNAMIC CONFIGURATION OF TB PARAMETERS AT EACH STAGE OF THE PROCESSING PATH
- ❑ TAKE INTO ACCOUNT DATA INFLATION BEHAVIORS
- ❑ GENERALIZED USAGE OF ENVELOPE PROCESSES, COMPARISON,...



PERSPECTIVES (2)



- ❑ TESTS WITH REAL COMPUTING CLOUD TESTBEDS/MIDDLEWARE
- ❑ DEMONSTRATOR INCLUDING REAL SENSING HARDWARE & GATEWAYS + COMPUTING CLOUDS TESTBEDS



CONCLUSIONS (2)



- ❑ DEFINE & SPECIFY NEEDS FOR SOUTH-ASIA PACIFIC COUNTRIES IN TERMS OF GLOBAL SENSING APPLICATIONS
- ❑ GRID/CLOUD TECHNOLOGY, COUPLED WITH GLOBAL SENSING...
 - ❑ ENVIRONMENTAL
 - ❑ ENERGY
 - ❑ DISASTER RELIEF
 - ❑ ...
- ❑ ...OPENS UP A LOT MORE PERSPECTIVES!